

ACTIVE HARMONIC MITIGATION – WHAT THE MANUFACTURERS DON'T TELL YOU

Copyright Material IEEE
Paper No. PCIC 2018-43

Anthony Hoevenaars, P.Eng
Member, IEEE
Mirus International Inc.
31 Sun Pac Blvd.,
Brampton, ON L6S 5P6
Canada
hoevenaars@mirusinternational.com

Marek Farbis
Member, IEEE
Mirus International Inc.
31 Sun Pac Blvd.,
Brampton, ON L6S 5P6
Canada
marek@mirusinternational.com

Mike McGraw
Member, IEEE
NSOEM
33427 Mayer Rd.
Waller, TX 77484
USA
m.mcgraw@nsoem.com

Abstract - Despite their high cost, active harmonic mitigation solutions, such as parallel Active Power Filters (APFs) and Active Front End Drives (AFEs), are growing in popularity. As the latest technology, they are being touted as a better choice than the various forms of passive harmonic mitigation solutions presently available. Is this actually the case? Active solutions incorporate switching strategies using IGBTs in order to make the current drawn by the adjustable speed drive, or other non-linear load, more sinusoidal. What you will rarely hear from manufacturers is that this switching introduces higher frequency harmonics, normally above the 50th. When measurements are taken up to the 50th, current total harmonic distortion (ITHD) is often quite low but when measured up to the 100th or higher, ITHD almost always exceeds their claimed performance levels which consider only harmonics up to the 50th. This is certainly a concern because higher frequency harmonics are more likely to cause power system problems and issues with other connected loads, than the lower frequency harmonics that they are designed to reduce.

Although there are IEEE and IEC industry standards that restrict levels of harmonics in the low frequency and very high frequency ranges, there are no standards presently that address the range between 2 kHz and 150 kHz. Manufacturers therefore, often design active harmonic mitigation equipment that generates relatively high levels of these mid-range frequencies, particularly since switching frequencies of IGBTs typically fall precisely within this range.

Index Terms — Active Power Filters (APF), Active Harmonic Filters (AHF), Active Front End Drives (AFE), Wide Spectrum Harmonic Filter (WSHF), harmonics, variable speed drive, supraharmonics.

I. INTRODUCTION

Active Power Filters (APFs) or Active Harmonic Filters (AHFs), as they are sometimes known, and Active Front End (AFE) Drives have emerged as new trends in harmonic mitigation technology for applications involving adjustable speed drives (ASDs). Technical publications for APFs date back to the 1980s while AFE technology appears around the same time. They are both capable of correcting power network harmonic distortion caused by power electronic, non-linear loads. APFs and AFEs require state-of-the-art power electronic switches and advanced control techniques to make the non-linear load appear near purely resistive.

The most popular implementation of active power filters

is the shunt APF that uses PWM voltage source inverter technology as its main strategy. Since voltage source inverters are a more popular alternative than current source inverters, only those will be addressed here. The shunt APFs are parallel connected and reduce harmonics and improve power quality by means of generating compensating current that matches the harmonic current required by the non-linear load. This compensating current is injected either near the load or at a carefully selected point in the electrical distribution, such as the point of common coupling or PCC.

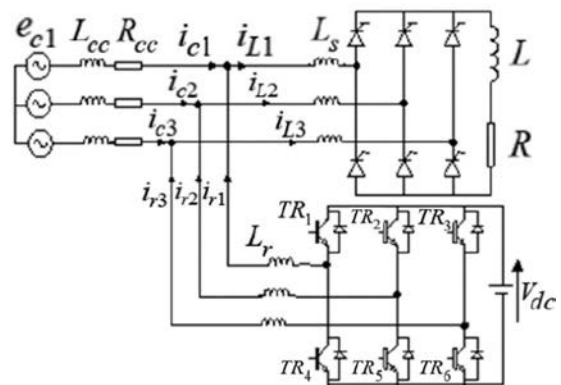

Fig. 1 Simplified diagram of shunt connected APF

AFEs, on the other hand, are series connected and are an integral part of the ASD. In an AFE drive, a pulse width modulated (PWM) rectifier replaces the simple diode bridge rectifier used in conventional ASDs. The PWM rectifier employs fully controlled IGBTs in essentially the same configuration as the drive's PWM output inverter. The IGBTs are controlled such that the drive draws current in a more sinusoidal manner, with substantially less current harmonics, rather than the typical pulsed current waveform of the diode bridge rectifier.

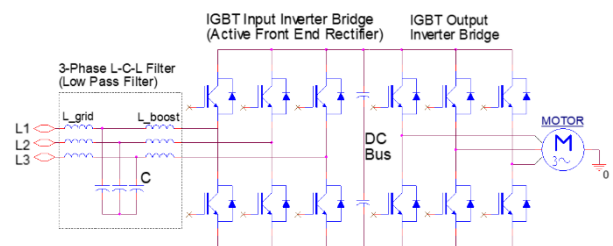

Fig. 2 Typical AFE Drive Schematic

Although there are many benefits of active harmonic mitigation techniques, there is one principle concern that manufacturers of this technology rarely discuss. That is, the relatively high levels of electromagnetic interference (EMI) that they introduce in the 2 kHz to 150 kHz range where no industry standard exists to limit these conducted emissions.

II. PROBLEMS WITH ACTIVE HARMONIC MITIGATION SYSTEMS

Although they have their benefits, active harmonic mitigation systems definitely have limitations, some of which can cause serious problems.

APFs possess certain disadvantages such as complex control structures, switching losses and EMC emissions (switching noise being present in the line current and the line voltage). The EMC emissions require that a low-pass passive filter (LCL) be included between the line and the APF. These filters are not always effective which can lead to the injection of high frequency switching harmonics into the power system.

Similarly, AFE Drives also have complex control structures and require the use of passive LCL filters. Some AFE Drive manufacturers will claim that their technology provides the best solution for treatment of harmonics associated with ASDs. They are quick to point out benefits over standard 6-Pulse ASDs such as, reduced line current harmonics, improved power factor and inherent regenerative capabilities. But they rarely mention the fact that current harmonics are much higher when measured above the 50th and that very serious problems can result from the introduction of these higher frequency harmonics. Also, they will downplay a substantial loss in efficiency due to the increased switching losses of the input IGBTs.

Problems associated with the application of active harmonic mitigation systems include:

1. Current harmonics much higher than claimed when measured above the 50th harmonic
2. High levels of voltage distortion when measured above the 50th harmonic
3. Connected equipment malfunction, including the AFE drives themselves and standard diode bridge front end drives
4. Failure of transformers and other power distribution equipment due to excessive losses at the IGBT switching frequencies. At one installation, a 2000 kVA transformer failed as a result of switching frequency harmonics above 10 kHz introduced by active power filters.
5. Stability and system resonance issues, especially with capacitors in the LCL and EMI filters or installed downstream for power factor correction
6. Higher losses and lower efficiencies than similarly rated 6 Pulse ASDs with passive harmonic filters

III. THE MISSING FREQUENCY BAND IN ELECTRICAL STANDARDS

When today's harmonic standards were first being established, the majority of power electronic equipment generating harmonics consisted primarily of diode and thyristor-based rectifiers. As such, the harmonics they generated followed very predictable characteristics. For phase-to-neutral 1-phase loads, the predominant harmonics were 3rd, 5th, 7th, and 9th. For phase-to-phase 1-

phase or 3-phase loads, the predominant harmonics were 5th, 7th, 11th and 13th. Harmonics above the 40th or 50th were almost never at levels that would cause problems and therefore harmonic standards only addressed the lower frequencies. In some jurisdictions, there were concerns about very high frequency conducted and radiated harmonics (above 150th) which led to standards that limited these emissions.

However, with the increasing use of high speed switching components in devices such as converters and inverters directly connected to the utility grid, harmonics in the range of 2 kHz to 150 kHz are becoming very common and troublesome. This is because lower levels of these higher frequency current harmonics can create high levels of voltage distortion and harmonic losses. And sometimes equipment can be sensitive to levels of distortion at these frequencies that are much lower than levels at the low frequency harmonics. In the opinion of the authors and others, it is now time to consider establishing standards in this missing frequency band [9][10][11][44][45].

A. IEEE Harmonic Standards

The latest revision of IEEE Std 519, 'Recommended Practice and Requirements for Harmonic Control in Electrical Power Systems' was released in March of 2014 [12]. This replaced the previous version that had been around since 1992. IEEE Std 519 was established to prevent harmonics generated by non-linear loads from negatively affecting the power system and connected loads. This standard has been widely adopted - particularly in North America but has recently become more commonly referenced in many other areas of the world.

IEEE Std 519 provides recommendations and guidelines for limiting harmonic voltage and current distortion at a point of common coupling (PCC) between the electrical system owner or operator and a user. The standard recognizes the responsibility of an electricity user to not degrade the voltage of the utility by drawing heavy nonlinear or distorted currents. It also recognizes the responsibility of the utility to provide users with a near sine wave voltage.

Recommended harmonic limits are found in Section 5 of the standard and are shown in Tables 1 and 2.

TABLE I
VOLTAGE DISTORTION LIMITS IN IEEE STD 519-2014 [12]

Bus voltage V at PCC	Individual harmonic (%)	Total harmonic distortion THD (%)
$V \leq 1.0$ kV	5.0	8.0
1 kV $< V \leq 69$ kV	3.0	5.0
69 kV $< V \leq 161$ kV	1.5	2.5
161 kV $< V$	1.0	1.5

TABLE 2
CURRENT DISTORTION LIMITS IN IEEE STD 519 FOR
SYSTEMS RATED 120 V THROUGH 69 kV [12]

Maximum harmonic current distortion in percent of I_L						
Individual harmonic order (odd harmonics)						
I_{SC}/I_L	$3 \leq h < 11$	$11 \leq h < 17$	$17 \leq h < 23$	$23 \leq h < 35$	$35 \leq h \leq 50$	TDD
< 20°	4.0	2.0	1.5	0.6	0.3	5.0
20 < 50	7.0	3.5	2.5	1.0	0.5	8.0
50 < 100	10.0	4.5	4.0	1.5	0.7	12.0
100 < 1000	12.0	5.5	5.0	2.0	1.0	15.0
> 1000	15.0	7.0	6.0	2.5	1.4	20.0

The definitions for total harmonic distortion (THD) for voltage and total demand distortion (TDD) for current require harmonic components up to the 50th be considered. On a 60 Hz system, that would be 3000 Hz. However, the definitions do recognize the fact that higher frequencies may need to be controlled as well by stipulating that, "Harmonic components of order greater than 50 may be included when necessary". The problem of course is, who determines when it is necessary – the manufacturer whose designs haven't taken this into consideration or the user who doesn't want to experience the problems that the higher order harmonics will cause?

Some important differences between revision 2014 and 1992 of IEEE 519 include:

1. THD and TDD definitions now allow the inclusion of harmonics above the 50th when necessary.
2. Voltage distortion limits for < 1kV systems have been relaxed to 8% from 5%.
3. Lower voltage distortion limits for Special Applications and higher limits for Dedicated Systems have been removed.
4. Current distortion limits for > 161kV systems have been changed. Current limits for other voltage systems remain the same.
5. Very Short Time and Short Time limits have been introduced.
6. An allowance for increased harmonic limits at higher frequencies can be applied when steps are taken to reduce lower frequency harmonics.

In the opinion of the authors, many of these changes have not been for the better. Particularly relaxing of the voltage distortion limits for < 1kV systems and allowing the increase of higher frequency harmonics when steps are taken to reduce harmonics at lower frequencies. The latter is particularly troublesome and is the focus of this paper.

B. IEC Harmonic Standards

IEC has various standards that apply to harmonics generated by non-linear loads. For lower frequency harmonics (up to the 40th), IEC 61000-3-2 defines limits for harmonic current emissions for equipment with input current <16A/phase single and 3 phase [13] while IEC 610003-12 defines these limits for equipment >16A and <75A [14]. It is worrisome that there are no specific IEC standards for non-linear loads above 75A because large non-linear loads inject higher levels of harmonic currents

which can cause more problems than those generated by smaller loads.

Unlike IEEE Std 519, these IEC standards apply limits on the loads themselves. Voltage distortion levels are not defined as they are addressed in IEC 61000-2-2, 'Compatibility levels for low-frequency conducted disturbances and signaling in public low-voltage power supply systems' and IEC 61000-3-6, 'Assessment of emission limits for the connection of distorting installations to MV, HV and EHV power systems' [15][16].

For high frequency harmonic limits, IEC 61800-3 is often used. Table 3 shows the limits in the frequency band from 150 kHz to 30 MHz from this standard. It is interesting to note that the standard does not provide limits for the frequency band from 9 kHz to 150 kHz but does mention that they are under consideration [17].

TABLE 3
IEC 61800-3 VALUES OF LIMITS FOR MAINS TERMINAL
DISTURBANCE VOLTAGE IN THE FREQUENCY BAND
150 kHz TO 30 MHz [17]

Size of PDS	Frequency band MHz	Unrestricted distribution		Restricted distribution	
		Quasi peak dB(μ V)	Average dB(μ V)	Quasi peak dB(μ V)	Average dB(μ V)
Low power drive system ($I < 25$ A)	$0,15 \leq f < 0,5$	66	56	79	66
		Decreases with log of frequency down to 56	Decreases with log of frequency down to 46		
	$0,5 \leq f \leq 5,0$	56	46	73	60
	$5,0 < f < 30,0$	60	50	73	60
Medium power drive system ($I \geq 25$ A)	$0,15 \leq f < 0,5$	79	66	79	66
	$0,5 \leq f \leq 5,0$	73	60	73	60
	$5,0 < f < 30,0$	73	60	73	60

C. Equipment Trend Towards Higher Frequency Harmonics

With the lower harmonic limits these standards impose for power electronic equipment, current harmonics are being reduced at least at the lower frequencies. Fig 4 shows this trend from measurements taken at large groups of computer users from 2002 to 2009 [44]. As can be seen, there has been a dramatic drop in emissions at the 3rd, 5th and 7th harmonics.

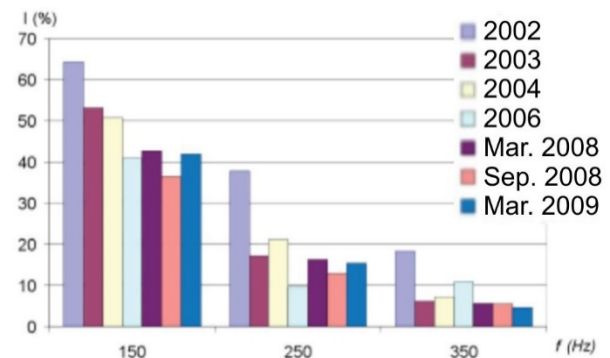

Fig. 4 Emission from a large group of state-of-the-art computers, 2002 through 2009 [44].

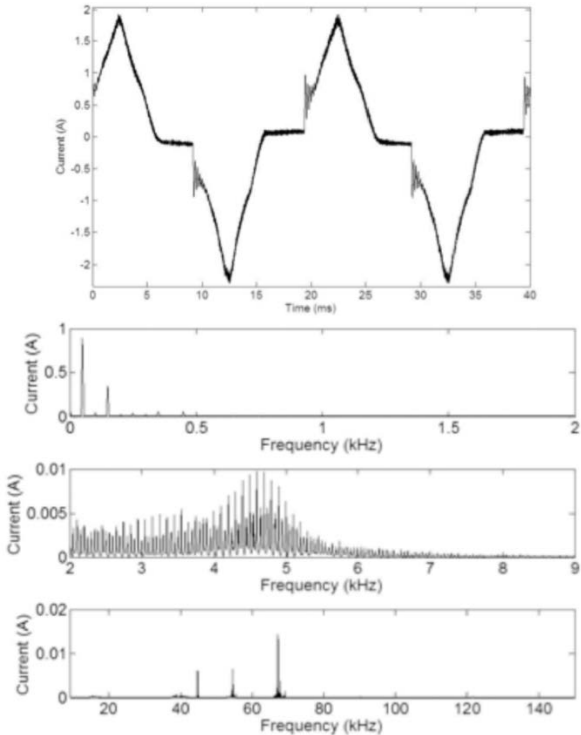

Fig. 5 Current waveform and spectrums for a modern television [44].

To further demonstrate this trend but also to highlight the introduction of higher frequency harmonics, Fig. 5 shows the current waveform and spectrums of a modern television [44].

Although the lower frequency harmonics are reduced (3rd is the highest at around 30%), relatively high levels of high frequencies appear near 5 kHz and 50 to 70 kHz. These higher frequency emissions did not appear in older technology using simple rectifiers on their Front Ends.

D. Supraharmonics: 2 kHz to 150 kHz

The graph in Fig. 6 shows the range of frequencies that each harmonic standard addresses. As can be seen, the frequency band between 2 or 3 kHz to 150 kHz is not covered by any standard. This frequency range is beginning to be referred to as ‘supraharmonics’ [44]. It is curious that this frequency band is not covered but, even more so, when we consider the fact that most power electronic switching devices, such as IGBTs, switch precisely within this band (2 kHz to 8 kHz or higher).

Also of concern in this band is that most instruments used to measure power quality indices only measure harmonics up to the 50th which is 2.5 kHz on a 50 Hz system and 3 kHz on a 60 Hz system. Therefore, they will

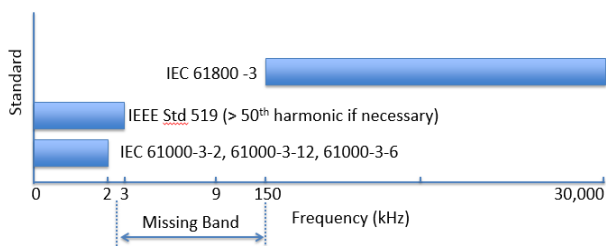

Fig. 6 Graph of frequencies covered by various harmonic standards

not detect high levels of harmonics in this frequency band because they lie above the 50th.

IV. PASSIVE FILTERS REQUIRED FOR ACTIVE HARMONIC MITIGATION EQUIPMENT

Since the IGBT switching frequencies, or carrier frequencies as they are often referred, appear in the input current of active devices, they must be controlled with the use of passive filters. At the switching frequencies themselves, these filters typically consist of an LCL network. At much higher, reflected frequencies, EMI/RFI filters are required.

This paper's focus is on the switching frequencies, so design requirements for the LCL filter will be discussed. One key consideration is the potential for power system resonance. If not suitably addressed, an LCL filter can resonate with the natural inductance of the source impedance resulting in high levels of both current and voltage harmonics.

V. LCL FILTER'S SUSCEPTIBILITY TO RESONANCE WITH THE POWER SYSTEM

Whenever capacitors are used in an electrical power system, they introduce the possibility of resonance. This is true for passive filters used to control the harmonics generated by 6-Pulse rectifier ASDs as well as the LCL filters used to control switching frequencies in active harmonic mitigation devices. Resonance with characteristic power system harmonics can be averted in 6-Pulse filters if the tuned frequency at the input is below the 5th harmonic, but exposure to system resonance is very difficult to prevent for LCL filters due to their higher tuned frequency values.

In order to control the IGBT switching frequency, an LCL filter is typically designed as a low pass filter with its ‘knee’ or cutoff frequency tuned comfortably below the switching frequency. For example, an AFE ASD that has an IGBT switching range of 2 to 8 kHz will require an LCL filter tuned comfortably below 2 kHz – often 1 kHz. On a 60 Hz system, 1 kHz is near the 17th harmonic. This typically allows the LCL filter to be smaller than a standard 6-Pulse rectifier filter.

However, this exposes the filter to resonance with the power system at a predominant harmonic, such as the 11th or 13th or lower. This is because the power system is almost always inductive which lowers the tuned frequency. A capacitive power system typically only occurs when overcompensated by power factor correction capacitors which should always be avoided because it can introduce many other issues.

Fig. 7 shows a simplified power system 1-line and its equivalent circuit. In this example, the non-linear load, the ASD, is represented as a current source of harmonics. Each current harmonic is injected into the power system and passes through the transformer reactance, X_{Th} , and then encounters the combined capacitive reactance, X_{Ch} , and system inductive reactance, X_{Svsh} , which is the paralleled combined inductance of the source and the other connected loads.

The parallel combination of the Power Factor Correction (PFC) capacitors and the system inductive reactance has a natural tuned frequency as shown in Fig 8. If the tuned frequency happens to be at a harmonic frequency that is prevalent in the power system, resonance will result in high levels of that harmonic in both current and voltage.

So why is it a problem when a passive filter is tuned to a frequency that is above the predominant power system harmonics but not when tuned below these frequencies? It stems from the fact that the power system is naturally inductive and as such, shifts the resonant frequency down towards the predominant harmonics. Fig. 9 shows how this occurs.

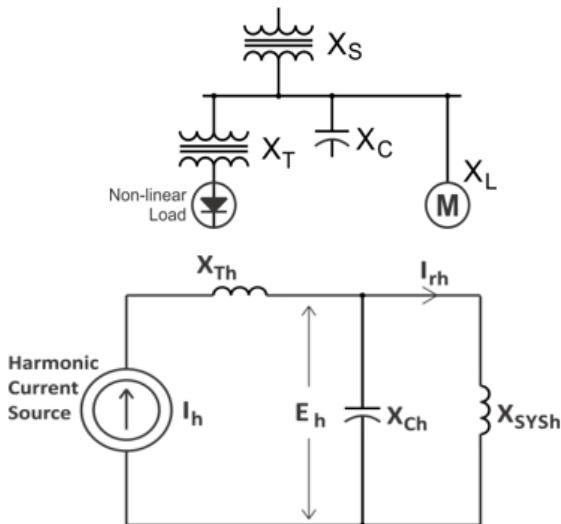

Fig. 7 1-Line and equivalent circuit of a simple power system with ASD non-linear load

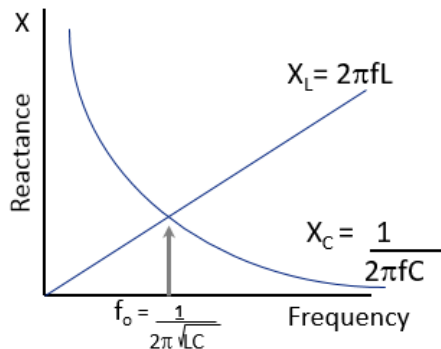

Fig. 8 Resonant frequency occurs at the point where the inductive reactance and capacitive reactance curves cross.

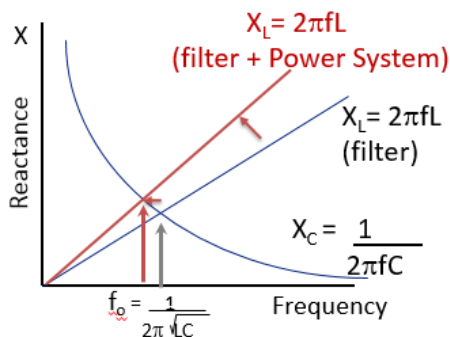

Fig. 9 Power system inductive reactance increases inductance reactance curve lowering resonant frequency

Therefore, any passive filter that is tuned above the predominant power system harmonics (ie. 5th, 7th, 11th, 13th) will be susceptible to resonance with these frequencies when connected to the power system. This is particularly true when the power systems are 'weak' (ie. high impedance) such as a relatively small Utility transformer or high impedance generator source. On the other hand, this is not a concern for a passive filter tuned below the predominant harmonics because the natural inductance of the power system will shift the resonance frequency lower and further way from the predominant harmonics.

To address this, various methods of damping oscillations at the LCL filter input have been proposed [37] - [43]. These include both passive and active methods. The passive approach uses a damping resistor that is connected in series or parallel with the filter inductor or capacitor. Although this method can stabilize the system, it causes excessive conduction losses that are undesirable because of a severe reduction in system efficiency.

One active method incorporates a virtual resistor [39]. A virtual resistor is an additional control algorithm that causes the LCL filter to behave as if a real resistor was connected. Since there is no real resistor in the circuit, the transient oscillations can be suppressed without sacrificing efficiency. However, this method requires an additional current or voltage sensor and a differentiator.

Both passive and active damping methods should be thoroughly tested since operating the converter under a resonance condition should always be avoided. In high source impedance environments, such as generators, it has been reported [43] that the AFE units with active damping may not even start the converter and therefore a hybrid method has been proposed to overcome this problem. A 1% passive damping resistor is used in series with the LCL filter capacitor and virtual resistor for an additional active damping algorithm. Although using only 1% passive damping resistor is enough to stabilize the system it is not enough to eliminate the resonance. The active damping method needs to be enabled for complete elimination of the resonance. [43]

VI. CASE STUDY 1: APF SWITCHING HARMONICS CAUSING FAILURE OF DC POWER SUPPLY

At a photovoltaic panel and solar inverter manufacturing plant in Toronto, Canada, a 450A active power filter was installed on the inverter test line in order to reduce the low frequency harmonics generated by the diode bridge rectifier used to generate DC power. Technicians on the photovoltaic panel test line located on a floor below, who were unaware of the APF installation, began to experience failure of a DC power supply in their PV tester each time the tester was powered on.

When power quality measurements were taken at the PV tester, it was discovered that the voltage waveform had a high frequency ripple (Fig. 10). Measured voltage distortion was < 1% which was well within the requirements of any harmonic standard yet the DC power supply was failing. Measurement of the power supply current, while operating at no load, gave clues to the reason why (Fig. 11). Harmonics in the voltage waveform between the 39th and 43rd were resonating with the DC power supply resulting in excessive currents at these frequencies being drawn by the power supply.

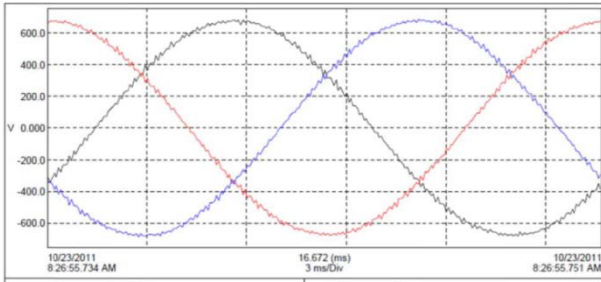

Fig. 10 Voltage waveform at PV Tester with high frequency ripple caused by APF (VTHD < 1%).

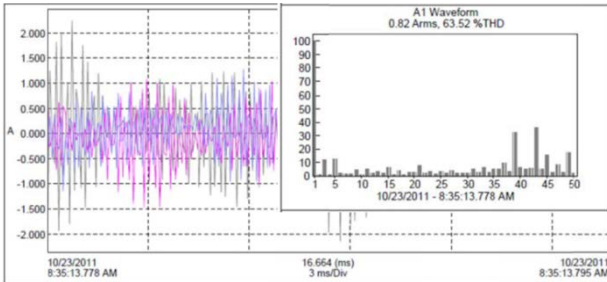

Fig. 11 Waveform and spectrum of no load current drawn by DC power supply with high frequency components.

To test this theory, the APF was turned off and repeat measurements taken at the PV tester. With the APF off, the ripple in the voltage waveform disappeared (Fig. 12) and the no load current of the DC power supply no longer contained the high frequency components (Fig. 13). When informed of the problem, the APF manufacturer tried replacing the reactor in its LCL filter but to no avail. Ultimately, the only solution was to permanently disable the APF which became a very expensive and useless piece of equipment.

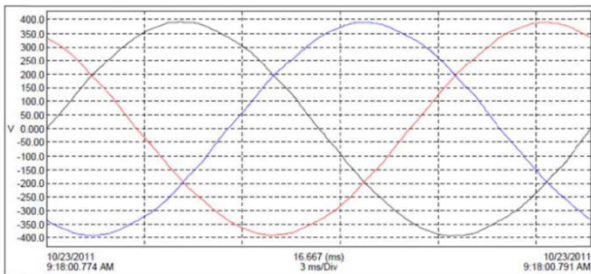

Fig. 12 Voltage waveform at PV Tester with APF off.

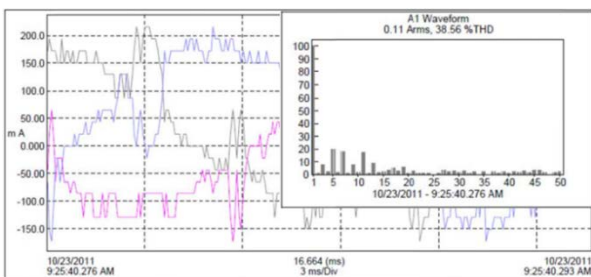

Fig. 13 Waveform and spectrum of no load current drawn by DC power supply with APF off.

VII. CASE STUDY 2: AFE DRIVE NOT MEETING ITHD REQUIREMENTS WHEN MEASURED TO 150TH HARMONIC

In an application where a relatively new AFE technology was being employed, measurements taken up to the 150th harmonic showed that the expected level of < 5% ITHD was not being met. In much the same way that the high speed switching of the IGBTs in the APF of Case Study 1 introduced a ripple on the voltage waveform, the devices in the AFE converter also created a ripple in the voltage waveform (Fig. 14). This ripple resulted from the harmonic voltage drops created when the high frequency currents drawn by the AFE passed through the impedance of the power system.

A view of the harmonic spectrum of the AFE's input current, shows that although current distortion was below 8% when measured up to the 50th harmonic, it exceeded this when harmonics up to the 150th were considered (Fig. 15). Actual total harmonic current distortion approached 10% while the expected level was to be < 5% ITHD.

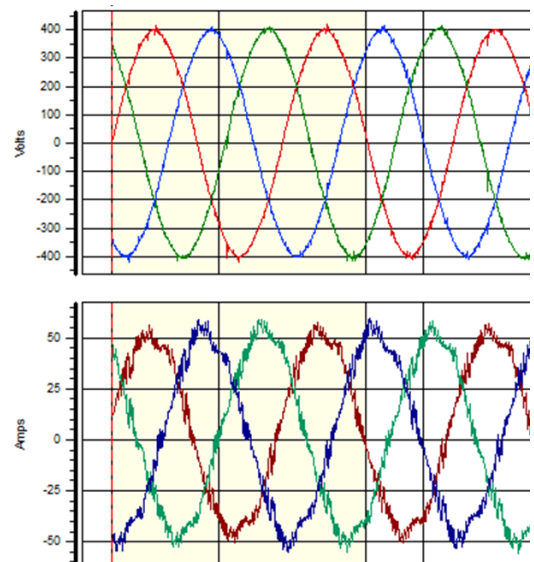

Fig. 14 Voltage and current waveforms at input of 40 HP (30 kW) AFE drive.

VIII. CASE STUDY 3: CATAMARAN EQUIPPED WITH MAIN AND AUXILLIARY PROPULSION AFE DRIVES [10]

Fig. 16 shows frequency spectrums of the voltage at the bridge distribution panel of a catamaran equipped with main and propulsion AFE Drives [10]. Measurements were taken over three frequency bands – up to 50th harmonic (Fig. 10a), 50th to 10 kHz (Fig. 10b) and 10 kHz to 50 kHz (Fig. 10c). A summary of the measurements is shown in Fig. 10d. Although the voltage harmonics were quite low in the lower frequency range (VTHD = 1.68%), they were very high in the frequency range above the 50th (VTHD = 8.14%) with a band around 3500 Hz (70th harmonic) produced by the AFE Drives operating at a 3.6 kHz switching frequency. Most power quality analyzers that only measure up to the 50th harmonic would not have highlighted these high distortion levels. These measurements were taken with a spectrum analyzer and highlight how one can be deceived into thinking harmonic distortion is low if only the low frequencies are considered.

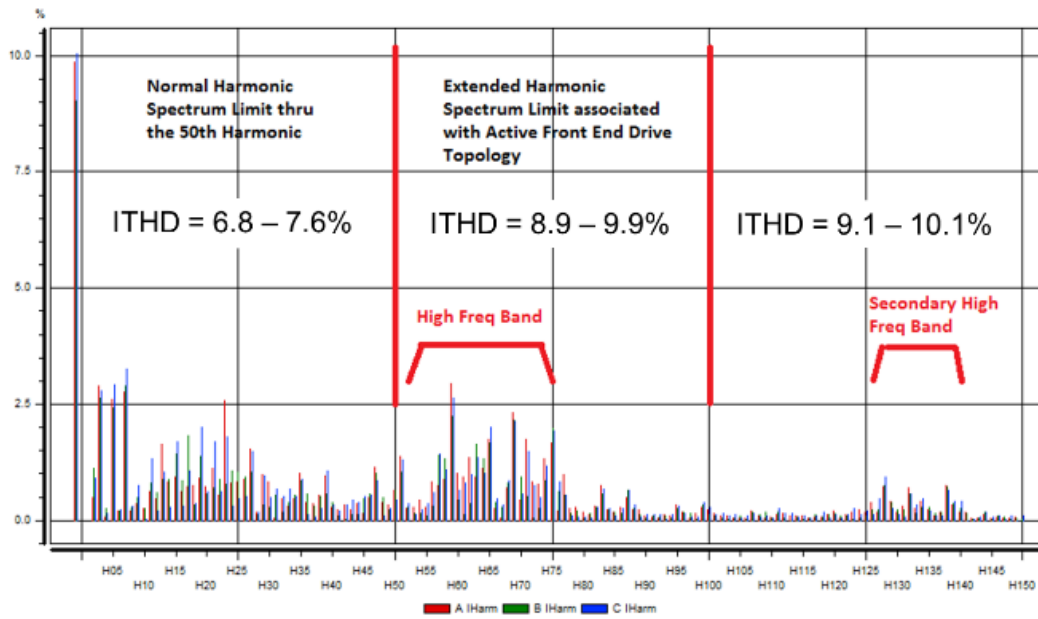

Fig. 15 AFE current harmonic spectrum measured up to the 150th harmonic.

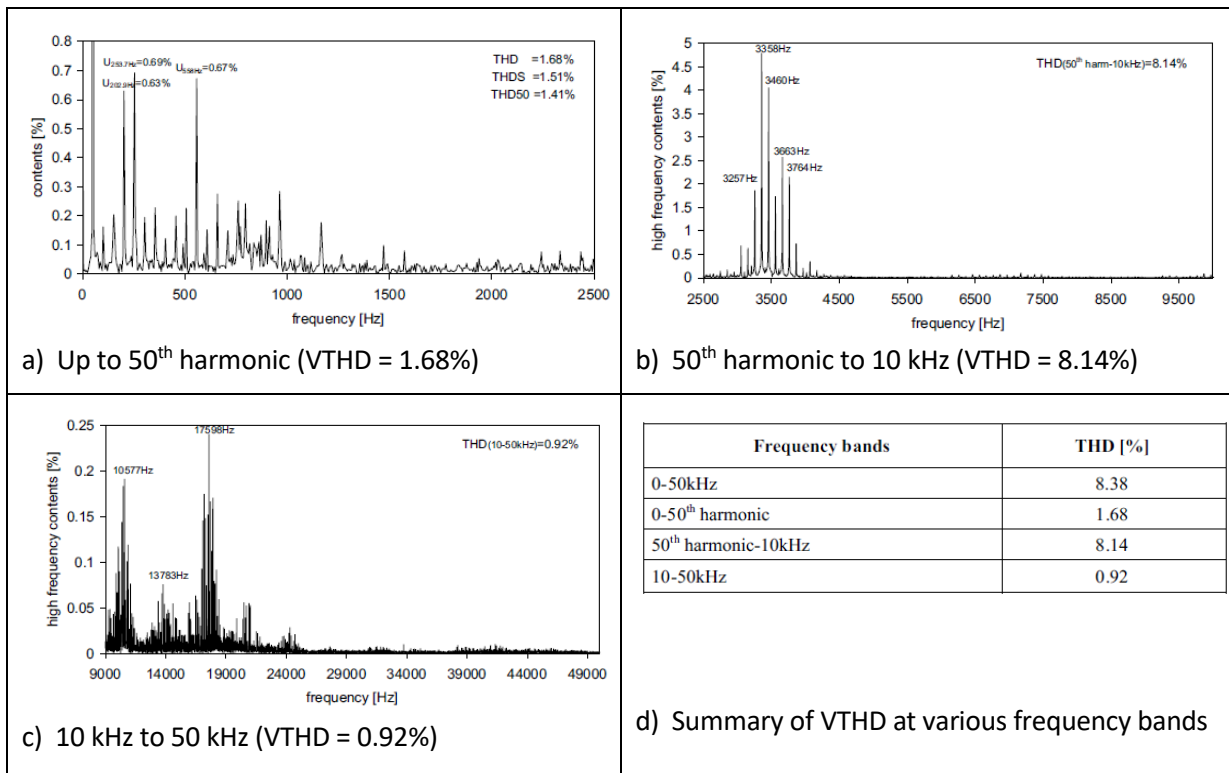

Fig. 16 Voltage harmonic spectrum of a catamaran with main and auxiliary propulsion AFE Drives [10]

IX. CONCLUSIONS

In an effort to reduce harmonic distortions in our power systems, standards limiting harmonic current emissions have been established by both IEEE and IEC. Unfortunately, these standards presently only target low frequencies (up to 50th harmonic) and very high frequencies (above 150 kHz). Today's active harmonic mitigation equipment, which includes Active Power Filters and Active Front End Drives, introduce switching frequency harmonics that fall into a band of frequencies that are not presently covered by any standards (ie. 2 kHz to 150 kHz). This allows manufacturers of this equipment to use relatively ineffective and inexpensive LCL passive filters.

By not filtering effectively, these active devices introduce high levels of distortion that can cause severe consequences, including those highlighted in the Case Studies. The more that these devices are being used, the more connected equipment problems arise due to these high distortion levels. Even relatively low % distortion levels can cause issues when the distortion is primarily at higher frequencies. Therefore, the use of AFE and APF technologies for harmonic mitigation, especially when connected to the public grid, requires thorough engineering of the application and a network analysis to understand potential resonance issues. Also, attention should be given to how well these devices attenuate the switching frequency harmonics they generate. In many cases, when low harmonics are the goal, a properly designed passive harmonic filter applied to a conventional 6-Pulse ASD still remains a better option.

Since there are no standards to refer to at the switching frequencies, it is recommended that harmonic limits should be applied at least up to the 100th harmonic when active harmonic mitigation solutions are used.

X. REFERENCES

- [1] H. Akagi, "New Trends in Active Filters for Power Conditioning", IEEE Transactions on Industry Applications, Vol. 32, No. 6, Nov/Dec. 1996
- [2] W. M. Grady, M. J. Samotyj, A. H. Noyola, "Survey of Active Power Line Conditioning Methodologies", IEEE Transactions on Power Delivery, Vol. 5, No. 3, July 1990
- [3] L. Asiminoaei, S. Kalaschnikow, S. Hansen, F. Blaabjerg, "Commutation effect of Adjustable Speed Drives due to installation of active harmonic filters", Proceedings of the 2011-14th European Conference on Power Electronics and Applications (EPE 2011), 30 Aug. 1 Sept. 2011
- [4] F. Z. Peng, "Application Issues of Active Power Filters", IEEE Industry Applications Magazine, Sep./Oct. 1998, pages: 21-30
- [5] M. Liserre, F. Blaabjerg, S. Hansen, "Design and Control of an LCL-filter based Three-phase Active Rectifiers", Industry Applications Conference, 2001. 36th IAS Annual Meeting. IEEE Conf. Rec. IAS, Chicago, USA, 2001. Pages: 299 - 307 vol.1
- [6] M. Malinowski, "Sensorless Control Strategies for Three-Phase PWM Rectifiers", Ph.D. Thesis, Warsaw University of Technology, Warsaw, 2001
- [7] Luis Moran, Jose Espinoza, Mauricio Ortiz, Jose Rodriguez, Juan Dixon, "Practical Problems Associated with the Operation of ASDs Based on Active Front End Converters in Power Distribution Systems", IEEE Transactions on Industrial Applications, 2004
- [8] "Guidance Notes on the Control of Harmonics in Electrical Power Systems", American Bureau of Shipping, May 2006
- [9] Janusz Mindykowski, Tomasz Tarasiuk, Mariusz Szveda, Ian C Evans, "Electric Power Quality Measurements on an All-Electric Ship with AC Active Front End Propulsion Drives", PRS Technical Report No. 68, Feb. 2007
- [10] M. Szveda, T. Tarasiuk, "An assessment of distortions of supply voltage waveform in All-Electric Ship Power Network - Case Study", 9th International Conference on Electrical Power Quality and Utilisation, Barcelona, 9-11 October 2007
- [11] J. Mindykowski, "Power quality on ships: Today and tomorrow's challenges", 2014 International Conference and Exposition on Electrical and Power Engineering (EPE), 16-18 Oct. 2014, pp: 1-18
- [12] IEEE Std 519-2014, *IEEE Recommended Practices and Requirements for Harmonic Control in Electrical Power Systems*, New York, NY: IEEE.
- [13] IEC 61000-3-2, *Limits for harmonic current emissions for equipment with input current <16A/phase single and 3 phase*.
- [14] IEC 61000-3-12, *Limits for harmonic currents produced by equipment connected to public low-voltage systems with input current >16A and < 75A per phase*.
- [15] IEC 61000-2-2, *Compatibility levels for low-frequency conducted disturbances and signaling in public low-voltage power supply systems*
- [16] IEC 61000-3-6, *Assessment of emission limits for the connection of distorting installations to MV, HV and EHV power systems*
- [17] IEC 61800-3, *Adjustable Speed electrical power drive systems – EMC product standard including specific test methods*
- [18] Ian C Evans, "AFEs: Not the Only Answer for Tackling Harmonics", Letter to the Editor, Drives & Controls magazine, Nov/Dec 2007
- [19] Ian C Evans, "Using Active Front End Drives – Substance or Spin", World Pumps magazine, July 2008
- [20] M. Bollen, M. Olofsson, A. Larsson, S. Ronnberg, M. Lundmark, "Standards for Supraharmonics (2 to 150 kHz)", IEEE Electromagnetic Compatibility Magazine – Vol. 3, Q1, 2014, pp 114 - 119
- [21] S. Schottke, J. Meyer, P. Schegner, S. Bachmann, "Emission in the Frequency Range of 2 kHz to 150 kHz caused by electrical vehicle charging", Proceedings of the 2014 International Symposium on Electromagnetic Compatibility (EMC Europe 2014), Sept. 2014, pp 620 - 625
- [22] CENELEC CLC/SC2015A, *Study Report on Electromagnetic interference between Electrical Equipment/Systems in the Frequency Range below 150 kHz, Edition 3*, Oct. 2015
- [23] S. Bernet, S. Ponnaluri, R. Teichmann, "Design and loss comparison of matrix converters and voltage source converters for modern ac-drives" IEEE Transactions of Industrial Electronics Society, 2002, Volume: 49, Issue: 2, Pages: 304 - 314.
- [24] J. R. Rodriguez; J. W. Dixon; J. R. Espinoza; J. Pontt; P. Lezana, "PWM regenerative rectifiers: state of the art" IEEE Transactions on Industrial Electronics, Year: 2005, Volume: 52, Issue: 1, Pages: 5 - 22.
- [25] B. Singh, K. Al-Haddad, A. Chandra, "A Review of Active Filters for Power Quality Improvement", IEEE Transactions on Industrial Electronics, Vol. 46, No. 5, October 1999, pages: 960-970.

- [26] F. Z. Peng, H. Akagi, A. Nabae, "A New Approach to Harmonic Compensation in Power Systems - A Combined System of Shunt Passive and Series Active Filters", IEEE Transactions on Industry Applications, Vol. 26, No. 6, Nov./Dec. 1990.
- [27] H. Akagi, Y. Kanazawa, A. Nabae, "Instantaneous Reactive Power Compensators Comprising Switching Devices without Energy Storage Components", IEEE Transactions on Industry Applications, Vol. IA-20, No.3, May/June 1984, pages: 625-630.
- [28] R. Wu, S. B. Dewan, G. R. Slemon, "A PWM AC-to-DC Converter with Fixed Switching Frequency", IEEE Transactions on Industry Applications, Vol. 26, No. 5, Sep./Oct. 1990, pages: 880-885.
- [29] M. Kazerani, P. D. Ziogas, G. Joos, "A Novel Active Current Waveshaping Technique for Solid-State Input Power Factor Conditioners", IEEE Transactions on Industrial Electronics, Vol. 38, No. 1, Feb. 1991.
- [30] R. Wu; S. B. Dewan; G. R. Slemon, "Analysis of an AC-to-DC voltage source converter using PWM with phase and amplitude control", IEEE Transactions on Industry Applications, Year: 1991, Volume: 27, Issue: 2, Pages: 355 - 364.
- [31] B. K. Bose, "Recent Advances in Power Electronics", IEEE Transactions on Power Electronics, Vol. 7, No. 1, Jan. 1992, pages: 2-16.
- [32] J. Dannehl, F. W. Fuchs, S. Hansen, "PWM Rectifier with LCL-Filter using different Current Control Structures", 2007 European Conference on Power Electronics and Applications, Pages: 1 - 10.
- [33] L. Asiminoaei; S. Hansen; C. Lascu; F. Blaabjerg, "Selective harmonic current mitigation with shunt active power filter", 2007 European Conference on Power Electronics and Applications, Year: 2007, Pages: 1 - 10.
- [34] Jaroslaw Luszcz, "High Frequency Harmonics Emission in Smart Grids", ISBN 978-953-51-1068-2, Chapter 11 of Power Quality Issues, Dr. Ahmed Zobaa (Ed.), InTech, DOI: 10.5772/52874. Available from: <https://www.intechopen.com/books/power-quality-issues/high-frequency-harmonics-emission-in-smart-grids>
- [35] S. Subhani, V. Cuk, J. F. G. Cobben, "A literature survey on power quality disturbances in the frequency range of 2-150 kHz", International Conference on Renewable Energies and Power Quality (ICREPQ'17), Malaga (Spain), 4th-6th April, 2017
- [36] J. Smith, S. Ronnberg, M. Bollen, J. Meyer, A. Blanco, K. Koo, D. Mushamaliwa, "Power Quality Aspects of Solar Power - Results from CIGRE JWG C4/C6.29", 24th International Conference on Electricity Distribution, Glasgow, 12-15 June 2017, Paper 0351.
- [37] V. Blasko; V. Kaura, "A novel control to actively damp resonance in input LC filter of a three-phase voltage source converter", IEEE Transactions on Industry Applications, Year: 1997, Volume: 33, Issue: 2, Pages: 542 - 550
- [38] M. Liserre; A. Dell'Aquila; F. Blaabjerg, "Stability improvements of an LCL-filter based three-phase active rectifier", Proceedings (Cat. No.02CH37289) 2002 IEEE 33rd Annual IEEE Power Electronics Specialists Conference. Year: 2002, Volume: 3, Pages: 1195 - 1201 vol.3
- [39] Pekik Argo Dahono, "A method to damp oscillations on the input LC filter of current-type AC-DC PWM converters by using a virtual resistor", in Proc. IEEE INTELEC Conf., Yokohama, Japan, 2003, pp. 757-761.
- [40] J. C. Wiseman and B. Wu, "Active damping control of a high-power PWM current source rectifier for line-current THD reduction", IEEE Trans. Ind. Electron., vol. 52, no. 3, pp. 758-764, Jun. 2005.
- [41] M. Malinowski, W. Szczygiel, M. P. Kazmierkowski, S. Bernet, "Sensorless operation of active damping methods for three-phase PWM converters", Proceedings of the IEEE International Symposium on Industrial Electronics, ISIE 2005. 20-23 June 2005, Dubrovnik, Croatia.
- [42] M. Malinowski, M. P. Kazmierkowski, S. Bernet, "New simple active damping of resonance in three-phase PWM converter with LCL filter", IEEE International Conference on Industrial Technology, 2005. ICIT 2005.
- [43] Y. P. Patel; A. S. Mohamed Sayed Ahmed; L. Wei, "Hybrid damping for active front end converter", 2016 IEEE Energy Conversion Congress and Exposition (ECCE), Year: 2016, Pages: 1 - 6.
- [44] M. Bollen, M. Olofsson, A. Larsson, S. Ronnberg, M. Lundmark, "Standards for Supraharmonics (2 to 150 kHz)", IEEE Electromagnetic Compatibility Magazine, Vol 3, Q1, 2014.
- [45] S. Schottke, J. Meyer, P. Schegner, S. Bachmann, "Emission in the Frequency Range of 2 kHz to 150 kHz caused by Electrical Vehicle Charging", 2014 International Symposium on Electromagnetic Compatibility (EMC Europe 2014), Sweden, Sept. 1-4, 2014.

XI. VITA

Anthony (Tony) Hoevenaars (BESc'79) is President and CEO of Mirus International Inc., Brampton, ON, Canada, a company specializing in the treatment of power system harmonics. Prior to joining MIRUS in 1996, he was the Chief Facilities Electrical Engineer at an IBM manufacturing facility in Toronto where he gained extensive experience in solving power quality related problems, particularly in the area of harmonics. Mr. Hoevenaars is a Professional Engineer and has published various papers on power quality including papers presented at the PCIC 2003, 2008, 2009, 2010, 2014, 2015 and 2016 conferences.

Marek Farbis graduated from Warsaw University of Technology in 1997 with Msc.E.E degree and specialty in Power Electronics. He has been a design engineer for the MEDCOM AC&DC Power Solutions and Traction Converters of Warsaw, Poland, company specializing in design of power electronic converters. In 2002 he immigrated to Canada working as Field/Service Engineer in the field of uninterruptible power systems and active harmonic filters. In 2008 he joined Mirus International Inc., Brampton, ON, Canada, providing expertise on power electronics, power conversion technologies and power quality issues. He is the Chief Applications and Power Electronics Engineer.

Michael McGraw is President of NSOEM Inc. a company he founded in 1996 that specializes in transformer and filter harmonic mitigation applications for land and offshore Oil & Gas systems and MV Solid State starting for large motors. Previously Mike was the OEM Sales Manager for MV Switchgear manufactured by Powercon Corp. Mike is a member of the IEEE and has published previous papers presented at the PCIC 2010, 2014, 2015 and 2016 conferences.

