

Rev. No.	Revision Note	Date	By	Checked
A5	FUSES REVISED	11-NOV-2013	AH	YM
A6	DESIGN UPDATED TO PRESSURE PLATE STYLE	09-MAR-2016	CG	AH

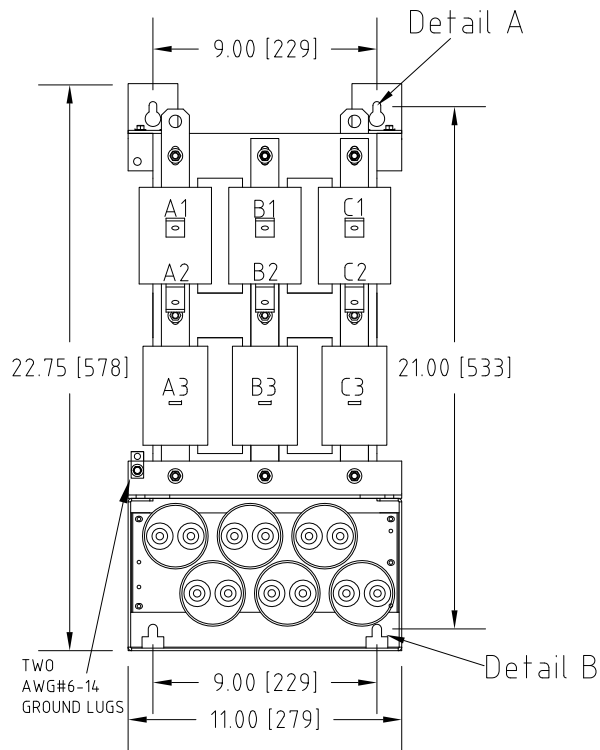

Front View

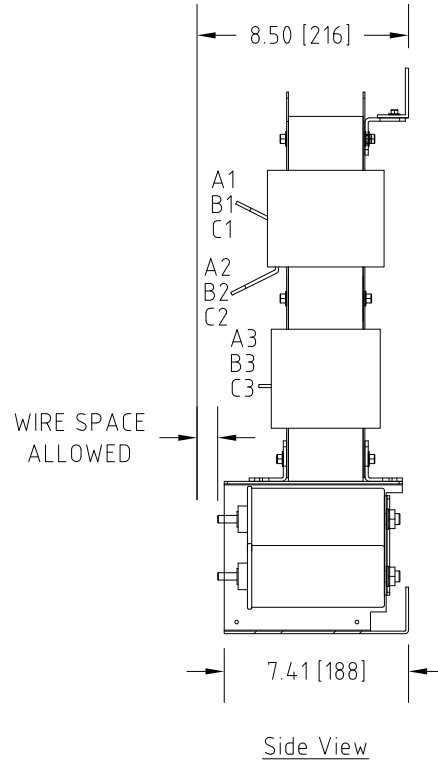

Side View

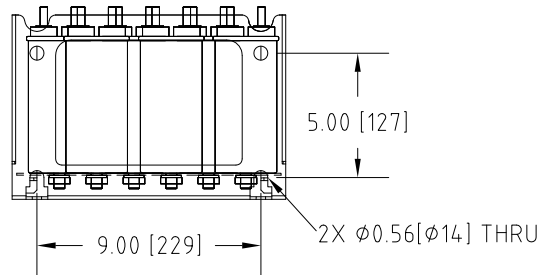

Bottom View

Connection Diagram

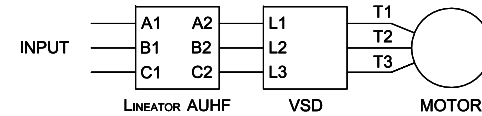

UNIT SPECIFICATIONS				INPUT	OUTPUT	APPROX. WT
HP [kW]	PHASE	VOLTS	Hz	AMPS	kW	lb [kg]
25 [18.5]	3	208	60	66	21	130 [59]

NOTES:

- CUSTOMER IS RESPONSIBLE FOR INSTALLATION TO MEET ALL NATIONAL AND LOCAL ELECTRICAL CODES AND OTHER APPLICABLE ELECTRICAL SAFETY AUTHORITIES.
- CUSTOMER IS RESPONSIBLE FOR PROPER COOLING OF FILTER COMPONENTS. ALLOWED AMBIENT: MAXIMUM 60°C, MINIMUM -40°C. A MINIMUM CLEARANCE OF 2" MUST BE ALLOWED ON BOTH RIGHT AND LEFT SIDES. PROPER VENTILATION MUST ENSURE THAT SUPPLY AIR FLOWS THROUGH THE REACTOR COILS FROM BELOW THE UNIT.

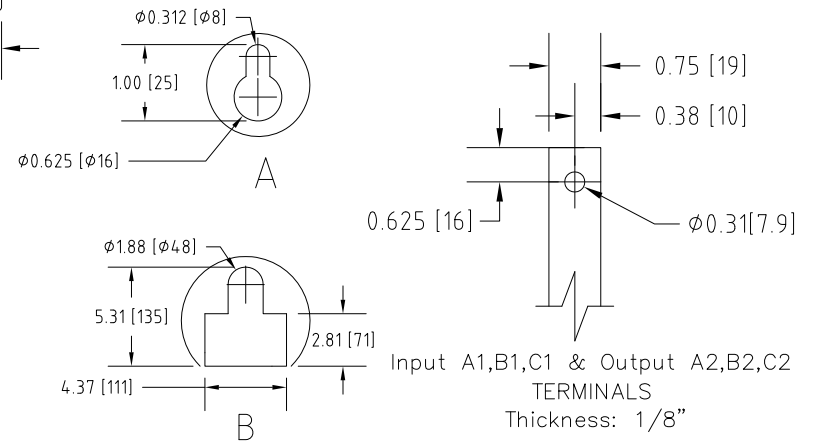

MIRUS International Inc.

31 Sun Pac Boulevard, Brampton, ON, Canada L6S 5P6
Tel: (905) 494-1120 Fax: (905) 494-1140 Toll Free: 1-888-TO MIRUS

Unless otherwise specified, dimensions are in inches and [mm].	Drawn by WXY	Date 20-NOV-09	Checked by YM	Approved by - date 20-NOV-09	Scale NTS
The information contained herein is the sole property of MIRUS International Inc. Any form of reproduction, distribution and/or disclosure of this information, all or in part, is strictly prohibited without the express written consent of MIRUS International Inc.		Title 25HP, 208V, 60 Hz Panel Mount Style Lineator AUHF			
		Filename AUHF-25-208-60-E0P-A6	Revision A6	Sheet 1/1	