

# INVERSINE™ Advanced Universal Sinewave Filter



## Key Features

- Low insertion loss and voltage drop (<3% of rated voltage)
- No damping resistors required
- Power delivered to motor >96%
- Efficiency >99%
- Improves Power Factor of the motor to near unity
- Provides reactive power compensation to motor
- Prevents transient overvoltages at motor terminals
- Reduces motor noise
- Filters out IGBT switching frequency currents
- Reliable and proven performance

## Inversine Applications

- When Motor does not have adequate insulation for ASD duty
- Using a number of parallel motors
- Long Motor cable length
- When Step-up/Step-down transformer is used between ASD and motor
- Specific requirements for peak voltage level and dV/dt rise time
- Motor noise needs to be reduced
- Maximum safety and reliability is needed in hazardous environments
- Submersible pumps with long motor cables used in the oil & gas industry or irrigation systems

## Problems Associated with PWM Inverter Operation

The Pulse Width Modulated (PWM) output voltage waveform of inverter equipped Adjustable Speed Drive (ASD) systems can greatly stress a standard induction or permanent magnet motor. This is primarily due to the rapid change in voltage (high dV/dt) produced by the inverter's switching action.

High dV/dt combined with a mismatch between cable and motor surge impedance can result in reflective wave phenomenon back at the motor terminals. Voltages can increase by as much as 2 to 3 times nominal peak levels possibly exceeding the insulation rating of the feeder cables and motor magnetic wire leading to insulation stress, partial discharges and eventual failure. This problem can result with short cable runs but becomes magnified with long cable runs.

Typical problems experienced can include motor and winding failure, motor noise, cable insulation degradation, premature ASD failure, common-mode and reflected wave phenomenon and high EMI/RFI.

## INVERSINE Differential Mode

The Inversine Advanced Universal Sinewave Filter (AUSF) is designed to address the problems resulting from pulse width modulation. It is a low pass filter with cutoff frequency well below the switching frequency of the inverter.

### *The AUSF is much more than a simple dV/dt filter and will:*

- substantially reduce voltage rise time (dV/dt)
- convert output voltage to near sinusoidal waveform (<3%)
- prevent transient overvoltages at motor terminals
- lower harmonic losses in the motor
- reduce motor noise
- reduce motor and cable insulation stress
- extend life of the motor and ASD

## INVERSINE Common-mode Option

Common-mode is the phase-to-ground voltage that appears as a result of the instantaneous sum of the 3-phase voltages of the PWM inverter not being zero even when the sum of the average 3-phase voltages is zero. Common-mode voltages will induce common-mode currents to flow through parasitic capacitance in the motor and motor feeder cable. High frequency capacitive coupling exists across the motor bearings and between the feeder conductor or motor winding and ground. Common-mode currents can lead to premature motor bearing failure and cable insulation breakdown.

### *The Inversine Common-mode Filter option will:*

- Reduce shaft voltage and bearing currents
- Reduce cable leakage currents
- Reduce common-mode voltages throughout power system



## Voltage Distortion



Typical PWM Variable Speed Drive (VSD) Output Voltage Waveform

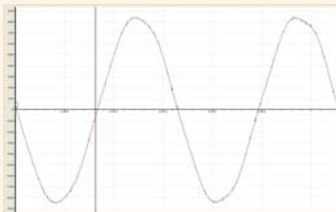

Output VSD Voltage Waveform with Inversine ( $V_{THD} < 3\%$  Typical)

## Current Distortion

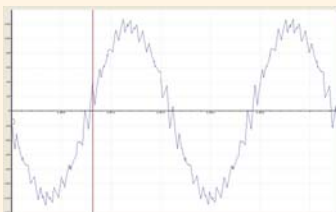

Typical VSD Output Current Waveform

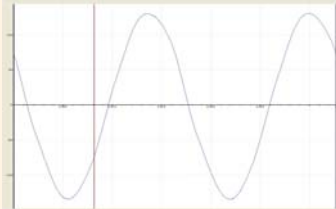

Output VSD Current Waveform with Inversine  $I_{THD} < 8\%$  Typical

## \* Near Unity Power Factor at Inverter

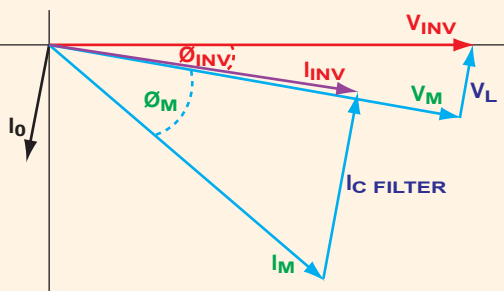

$V_{INV}$  = Voltage at Inverter output

$V_M$  = Voltage at motor

$V_L$  = Voltage drop across filter and cables

$I_{INV}$  = Current at Inverter output

$I_M$  = Current at motor

$I_{C\_FILTER}$  = Capacitive current of Inversine Filter

## The Inversine Advantage

### Highest level of filtering performance (<3% $V_{THD}$ )

The Inversine filter converts the voltage on the output of a variable speed drive from the PWM waveform to a sinusoidal waveform with less than 3%  $V_{THD}$ . Other competitor sinewave filters will still produce  $V_{THD}$  of 5-10% or even higher especially when frequencies above 50th harmonic are considered.

### Voltage drop lower than with an output line reactor (<3%)

Voltage drop should be considered when sizing motors and drives. The inverter needs to provide an increased voltage or current to compensate for the voltage drop of the filter (<3% for Inversine filter). Other competitor sinewave filters typically introduce a voltage drop in the range of 10%, which can reduce the power delivered to the motor to as much as 81% of nominal.

### Lower kVA requirement of the inverter

(Improves the power factor to 0.97-1.00)\* (see 'Near Unity Power Factor at Inverter' diagram below)

The capacitor bank design of the Inversine filter improves the motor PF as seen at the inverter output to near unity. This reduces the actual RMS current that the inverter must provide for the motor, significantly offloading the inverter.

### Highest efficiency (>99%)

Inherently damped design not requiring damping resistors, and low-loss reactor design, gives the Inversine higher efficiency than other sinewave filters.

### Available for Operating Frequencies up to 400Hz

Motors such as permanent magnet, can operate at frequencies much higher than 50 or 60Hz. Filtering for these higher frequencies requires unique designs and higher minimum inverter switching frequencies. Mirus offers models ideal for these challenging applications.

## Application Examples:

### Long cable length between drive and motor



Long cable lengths combined with a high dV/dt PWM waveform cause motor terminal overvoltage spikes due to reflective wave phenomenon. This occurs due to the impedance mismatch between the cables and the characteristic motor impedance.

Without a sinewave filter, overvoltage spikes can result in more than 2x the maximum DC bus rated voltage. The Inversine filter can be used in applications with cable lengths up to 15,000ft (4,572m) depending on the motor size.

### Drive feeding multiple motors in parallel

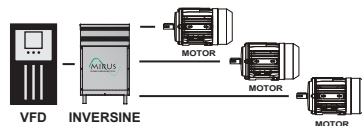

A sinewave filter is recommended to reduce the capacitive leakage currents between the cables to ground, and also the motors to ground. Sinewave filter with common mode option is recommended.

### Step-up or Step-down transformer between drive and motor

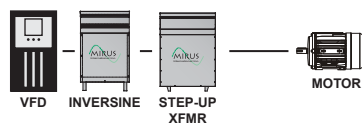

To avoid insulation stress and overheating of the transformer, a sinewave filter should be installed between the drive and the transformer to feed the transformer with a sinusoidal waveform.

### Motor noise needs to be reduced

Sinewave filters reduce motor noise, vibration and heat caused by drive switching frequency. This extends the life of motors by reducing bearing and insulation stress. Add common mode option if motor bearing failure is a concern.

### Retrofit drive installation

Sinewave filters are recommended when installing variable speed drives on older motors not intended for use with inverter PWM output waveforms (not rated to Mg1 Part 31). Without a sinewave filter, the motor's insulation may not be adequate, even in applications with shorter cable runs. Additional common-mode option can increase motor life even further.

# General Specifications:

## Voltage

Standard voltage up to 690V,  
3-phase, 60 or 50Hz models

## Overload Capability

Suitable for overload of 150% for  
60 seconds every 60 minutes

## Switching Frequency

1kHz to 16kHz model dependent  
(see Selection/Sizing)

## Motor Frequency

Up to 400Hz model dependent  
(see Selection/Sizing)

\*Contact factory for higher motor frequency, up to 400Hz

## Voltage Distortion (THD)

3% typical (Max. 5%)  
(at full load and at rated frequency)

## Input Current Distortion

<8% at full load

## Efficiency

3 to 15HP: >99%  
20 to 700HP: >99.3%  
800 to 1600HP: >99.5%

## Winding Material

Copper

## Operating Ambient Temperature

-20°C to +40°C (-4°F to 104°F)

## Elevation

≤ 1000m (3300ft) above sea level  
\*for higher elevation, please contact factory for -ED model

## Ventilation

Convection air cooled

## Enclosure

Type: Nema-3R, ventilated  
Paint: Polyester powder coated  
Colour: ANSI 61 Grey  
Wall Mtg. Capability: 5 to 75HP

## Options

Nema-3R Enhanced Outdoor Ventilated

## Typical INVERSINE™ Configuration

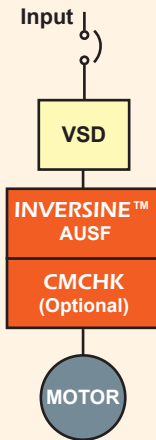

AUSF Rating Table [60Hz]

Motor Size		Output Amps [A] 3Ph/60Hz			Case*	Weight**
HP	kW	480V	600V	690V	Style	lbs [kg]
5	3.75	7.6	6.1	5.5	SU1	36 [16]
7.5	5.5	11	9	7.6	SU1	43 [20]
10	7.5	14	11	10	SU1	50 [23]
15	11	21	17	15	SU1	64 [29]
20	15	27	22	19	SU2	77 [35]
25	18.5	34	27	24	SU2	90 [41]
30	22	40	32	28	SU2	103 [47]
40	30	52	41	36	SU3	128 [58]
50	37.5	65	52	45	SU3	151 [68]
60	45	77	62	54	SU4	173 [78]
75	55	96	77	67	SU4	205 [93]
100	75	124	99	86	MT3	253 [115]
125	90	156	125	109	MT3	296 [134]
150	110	183	146	128	MT3	335 [152]
175	132	216	173	151	MT3	370 [168]
200	150	244	195	171	MT3	405 [184]
250	185	302	242	212	MT4	468 [212]
300	220	361	289	254	MT4	526 [239]
350	250	416	337	296	MT4	581 [264]
400	315	488	395	360	MT4	634 [288]
450	355	550	445	403	MT4	681 [309]
500	400	617	499	452	MT4	728 [330]
600	450	694	562	493	LT1	978 [444]
700	500	805	644	575	LT1	1109 [503]
800	560	920	736	653	LT1	1278 [580]
900	630	1035	828	735	LT1	1375 [624]
1000	710	1137	920	817	LT2	1533 [695]
1100	800	1250	1012	898	LT2	1650 [748]
1200	900	1371	1110	985	LT2	1769 [802]
1300	970	1478	1182	1050	LT3	1937 [879]
1400	1000	1591	1273	1130	LT3	2000 [907]
1500	1120	1706	1365	1212	LT3	2059 [934]
1600	1200	1828	1463	1299	LT3	2114 [959]

AUSF Rating Table [50Hz]

Motor Size		Output Amps [A] 3Ph/50Hz		Case*	Weight**
HP	kW	400V	440V	Style	lbs [kg]
5	3.75	9.7	8.8	SU1	58 [26]
7.5	5.5	13	12	SU1	67 [30]
10	7.5	17	16	SU2	78 [35]
15	11	25	23	SU2	90 [41]
20	15	33	30	SU2	118 [54]
25	18.5	41	37	SU2	130 [59]
30	22	48	44	SU2	142 [65]
40	30	63	58	SU3	154 [70]
50	37.5	78	72	SU3	186 [84]
60	45	93	85	SU4	218 [99]
75	55	115	106	SU4	304 [138]
100	75	160	137	MT3	323 [147]
125	90	186	170	MT3	345 [156]
150	110	222	204	MT3	365 [166]
175	132	262	240	MT3	390 [177]
200	150	296	271	MT3	415 [189]
250	185	368	337	MT4	578 [262]
300	220	441	404	MT4	585 [266]
350	250	515	471	MT4	651 [295]
400	315	625	572	MT4	700 [318]
450	355	700	641	MT4	783 [355]
500	400	785	718	LT1	865 [392]
600	450	856	784	LT1	980 [445]
700	500	998	914	LT1	1165 [528]
800	560	1135	1039	LT2	1380 [626]
900	630	1277	1169	LT2	1591 [722]
1000	710	1419	1299	LT3	1788 [811]
1100	800	1560	1429	LT3	1895 [860]
1200	900	1711	1567	LT3	1978 [897]
1300	970	1823	1669	LT3	2056 [933]
1400	1000	1963	1797	LT4	2408 [1092]
1500	1120	2105	1927	LT4	2540 [1152]
1600	1200	2255	2065	LT4	2613 [1185]

\* Case style may vary one size up or down depending on voltage model/frequency of filter  
\*\* Estimated values.

## Selection / Sizing

- The AUSF filter size should be selected such that the filter rated current is equal to or greater than the nominal motor current. Alternately, the filter may be selected by motor HP/kW rating, as long as the motor amps are equal to or lower than the NEC motor ratings table.
- In applications where the filter feeds an isolation transformer, size the filter so the filter amps rating is equal to or greater than the transformer primary rated current.
- Select the filter model according to operating frequency. A minimum switching frequency will apply based on the operating frequency.
- In applications where a single filter feeds multiple motors, size the filter so the filter amps rating is equal to or greater than the combined nominal motor currents.

### Product Code:

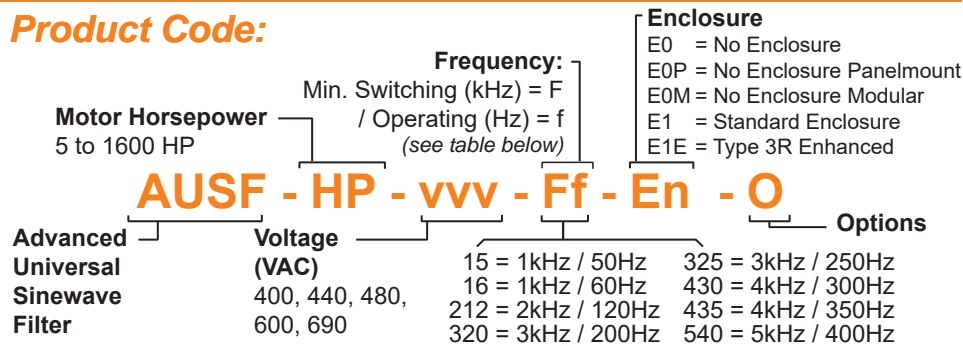

### Add-on Option:

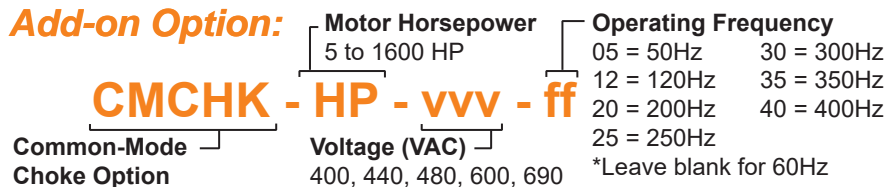

## Expect better. Call us.

To discuss how MIRUS can help you meet your power quality challenges, contact us at our head office:

MIRUS International Inc.  
31 Sun Pac Blvd.  
Brampton, Ontario  
Canada L6S 5P6

Tel: (905) 494-1120  
Fax: (905) 494-1140  
Toll-Free: 1-888-TO MIRUS (888-866-4787)

www.mirusinternational.com

MIRUS Electromagnetic Equipment Co., Ltd.  
Suzhou, Jiangsu China

Tel : (86) 0512-62696858  
Fax : (86) 0512-62696266  
www.cn.mirusinternational.com



## Harmonic and Energy Solutions

Real-world performance  
for real-world loads.

### 'SU' Style Enclosure

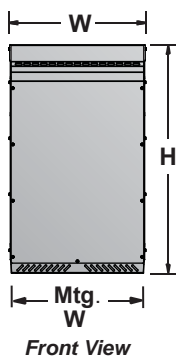

### 'MT', 'LT' Style Enclosure

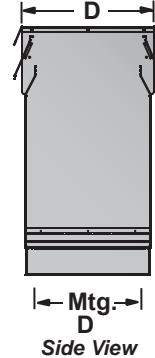
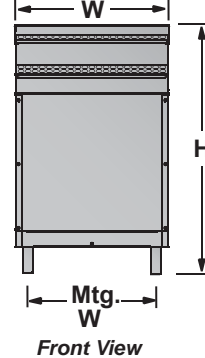

### Dimensions

Case Style	H (Height) inches [mm]	W (Width) inches [mm]	D (Depth) inches [mm]	Mtg. Center W inches [mm]	Mtg. Center D inches [mm]
SU1	23.50 [597]	11.25 [286]	11.25 [286]	9.00 [229]	9.50 [241]
SU2	30.00 [762]	13.25 [336]	12.75 [324]	11.00 [279]	11.25 [286]
SU3	34.00 [864]	20.25 [514]	16.00 [406]	18.00 [457]	14.25 [362]
SU4	40.00 [1016]	22.00 [559]	22.00 [559]	20.00 [508]	20.00 [508]
MT3	45.00 [1143]	26.00 [661]	21.00 [534]	21.50 [546]	19.00 [483]
MT4	51.50 [1308]	32.00 [813]	25.50 [648]	23.50 [597]	23.50 [597]
LT1	59.00 [1499]	39.50 [1003]	30.00 [762]	24.00 [610]	32.00 [813]
LT2	66.00 [1677]	44.00 [1118]	34.00 [864]	26.00 [660]	36.00 [915]
LT3	75.00 [1905]	48.50 [1232]	39.00 [991]	27.50 [699]	41.00 [1041]
LT4	78.00 [1981]	58.50 [1486]	50.50 [1283]	32.00 [813]	52.00 [1321]