

#### GENERAL SPECIFICATIONS:

##### PRIMARY Voltage, Phase, Frequency

120/208V, 3-phase 4-wire, 60Hz

##### SECONDARY Voltage, Phase, Frequency

120/208V, 3-phase 4-wire, 60Hz

##### OPERATING TEMPERATURE RISE

130°C [115°C] [80°C]

##### INSULATION CLASS

220°C

##### ANGULAR DISPLACEMENT

30° lag [0° lag]

##### OUTPUT ZERO SEQUENCE IMPEDANCE

$Z_0 < 0.95\%$ ,  $X_0 < 0.3\%$

##### SHORT CIRCUIT IMPEDANCE

1.0 – 2.0%

##### PRIMARY TAPS

± 1 x 5%

##### K-FACTOR CAPABILITY

20

##### CREST FACTOR CAPABILITY

4.5

##### NEUTRAL BUS AMPACITY

200% of phase current or  
300% with FAI

##### FULL LOAD EFFICIENCY

> 97%

##### MAGNETISING INRUSH

< 10 times FL RMS

##### WINDING MATERIAL

Copper

##### INSULATING VARNISH IMPREGNATION

Polyester Resin

##### AUDIBLE SOUND LEVEL

As per NEMA ST-20 & CSA C9

##### ENCLOSURE

Type: NEMA-3R, ventilated

Paint: Polyester powder coated

Colour: ANSI 61 Grey

##### NEUTRAL CURRENT AMMETER<sup>(1)</sup>

Flush mounted

#### OPTIONS:

##### FIELD ADJUSTABLE IMPEDANCE (FAI)

Selecting FAI option lowers input  $Z_0$  to permit input side neutral current treatment<sup>(5)</sup>

##### OVER-TEMPERATURE SWITCH(ES)

[170°C] [200°C]

##### SOLID BOTTOM PLATE (Case 'MT' only)

[yes], [no]

##### CAPACITIVE REACTIVE COMP.

[CRC] Compensation for leading PF load.

#### 'MT1', 'MT2' ENCLOSURE DIM. - inches [mm]

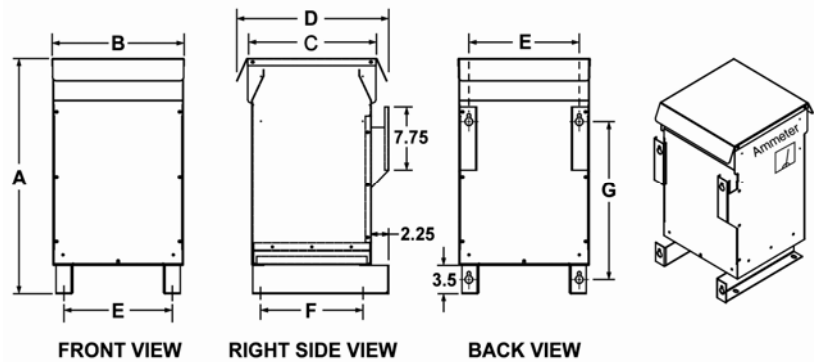

CASE	A	B	C	D	E	F	G
MT1	29.00 [737]	16.75 [425]	15.00 [381]	19.00 [483]	13.75 [349]	13.00 [330]	19.50 [495]
MT2	38.00 [965]	21.50 [546]	19.50 [495]	23.50 [597]	17.00 [432]	17.50 [445]	25.00 [635]

#### 'MT3', 'MT4', 'LT1' ENCLOSURE DIM. - inches [mm]

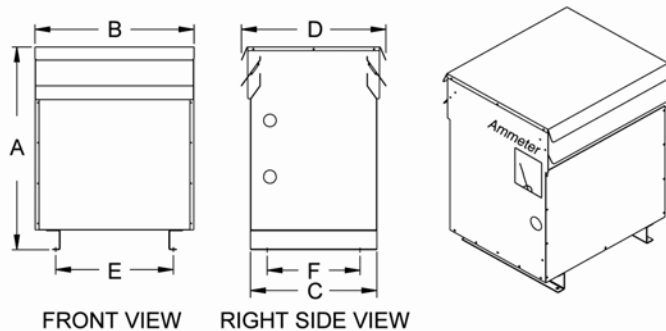

CASE	A	B	C	D	E	F
MT3	45.00 [1143]	26.00 [661]	21.00 [534]	25.00 [635]	21.50 [546]	19.00 [483]
MT4	51.50 [1308]	32.00 [813]	25.50 [648]	29.50 [749]	23.50 [597]	23.50 [597]
LT1	59.00 [1499]	39.50 [1003]	30.00 [762]	34.00 [864]	24.00 [610]	32.00 [813]

#### Product Code:

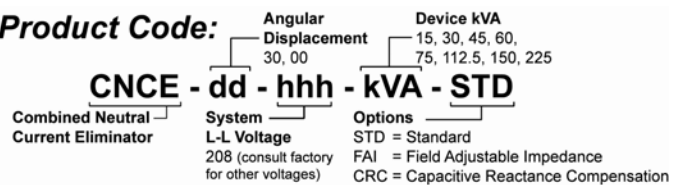

kVA Pri.	Sizes		Efficiency @35%-65% Load	Connections for 120/208V CNCE-STD <sup>(1)</sup>						O.C. Protection Suggested CB at 120/208V (Not Included)	
	Max. Inductive Reactive Power, Q (kVAR) <sup>(8)</sup>	Case Style		Weight lb [kg] <sup>(2)</sup>	Mechanical Lugs Provided			Suggested Conductor Sizes (Copper 75°C, in conduit) <sup>(6)</sup>			
				Input Phase & Neutral	Output Phase	Output Neutral	Input Phase & Neutral	Output Phase	Output Neutral		
15	1.5	MT1	230 [104]	97.0%	#2-#14	#2-#14	1/0-#14	#6	#6	#2	50A
30	3.0	MT2	320 [145]	97.5%	1/0-#14	2/0-#14	250MCM-#6	#2	#1	4/0	100A
45	4.5	MT2	410 [186]	97.7%	250MCM-#6	250MCM-#6	350MCM-#6	2/0	3/0	350MCM	150A
60	6.0	MT3	470 [213]	97.8%	250MCM-#6	250MCM-#6	2x250MCM-#6	4/0	250MCM	2x250MCM	200A
75	7.5	MT3	540 [245]	98.0%	350MCM-#6	350MCM-#6	2x350MCM-#6	250MCM	350MCM	2x350MCM	250A
112.5	11.25	MT4	700 [318]	98.2%	2x250MCM-#6	2x250MCM-#6	4x250MCM-#6	2x4/0	2x250MCM	4x250MCM	350A
150	1.5	MT4	890 [404]	98.3%	2x250MCM-#6	2x350MCM-#6	4x350MCM-#2	2x250MCM	2x350MCM	4x350MCM	500A
225	2.25	LT1	1350 [612]	98.5%	None (N4) <sup>(3)</sup>	None (N4) <sup>(3)</sup>	None (N4) <sup>(3)</sup>	2x500MCM	3x350MCM	6x350MCM	750A

1. Ammeter displays amount of neutral current removed from the system by the CNCE™.

2. For additional information refer to: Typical Specifications, Technical Guide, Internal Layout and Connection Diagrams.

3. [N4] = Busbar drilled with Nema 4-hole pattern, no lugs included.

4. Specifications are subject to change without notice.

5. CNCE-FAI shipped with high input  $Z_0$  selected (T1-T2 jumper open, folded back to T1). Consult factory before closing jumper.

6. End user is responsible for ensuring that the CNCE installation and wiring satisfies all applicable electrical and safety code requirements.

7. For CNCE-FAI model, use CNCE-STD output cable and lug sizes for both input and output, because triplen harmonics will be attracted to both input and output.

8. Max. inductive reactive power (Q) applies to CRC Option only. Provides inductive reactive power to compensate for leading PF loads.

