

# COORDINATED SURGE PROTECTION (CSP)



Potentially damaging voltage transients, spikes and surges in heavy industrial environments and remote location installations can commonly occur due to lightning, source capacitive switching, upstream large system load changes and circuit equipment inrush events; potentially compromising the drive branch circuit and its components.

The CSP option consists of an integrated surge protection device (SPD) designed to augment the harmonic filter's natural surge suppressive characteristics. The combination of a harmonic filter and CSP device further reduces the transient let through voltage, ensuring optimal protection to the power/electronic components of the VFD/VSD loads. CSP is also available on the full range of harmonic mitigating and Ultra low loss transformers for protection of the downstream connected equipment.

## FEATURES

- Low impedance internal circuitry designed with very low let through voltage levels coordinated below most harmonic filtered drive circuit withstand limits.
- Factory integrated with harmonic filters and transformers, and installed with the shortest practical lead length to maintain a low let-through voltage.
- LED status lights factory installed on enclosure exterior.
- Two types of fusing: Component level thermal fusing and phase level fault current fusing.
- Metal oxide varistor (MOV) design with fast reaction time (<1ns).
- Also suitable for distribution and sub-panels
- System compatible SCCR rating of 200kAIC
- Maintenance free operation



## PRODUCT QUALIFICATIONS

- Listed to ANSI/UL 1449-2006 (3<sup>rd</sup> Edition) by CSA; CE, IEC 61643-1, ANSI C62.72-2007 Compliant
- Test results to ANSI/IEEE C62.41 & C62.45

## WARRANTY

- 15 Years Unlimited Free Replacement on CSP component
- When factory installed on Lineator AUHF product, the complete AUHF filter product warranty is increased by an additional 24 months (5 years total).

# TYPICAL CONNECTION DIAGRAM

## AUHF INSTALLATION

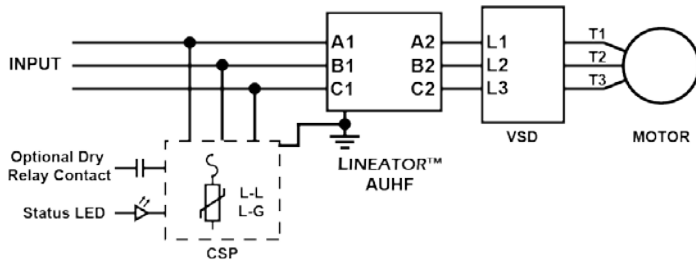

## XFMR INSTALLATION

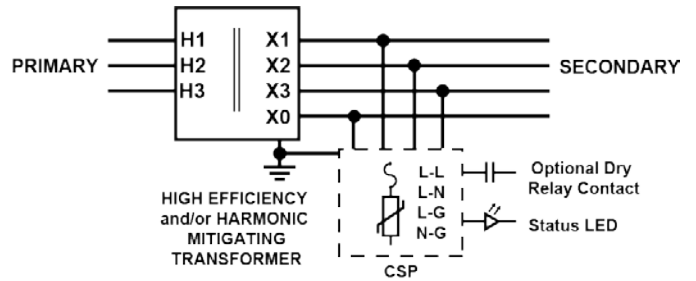

## PRODUCT CODE

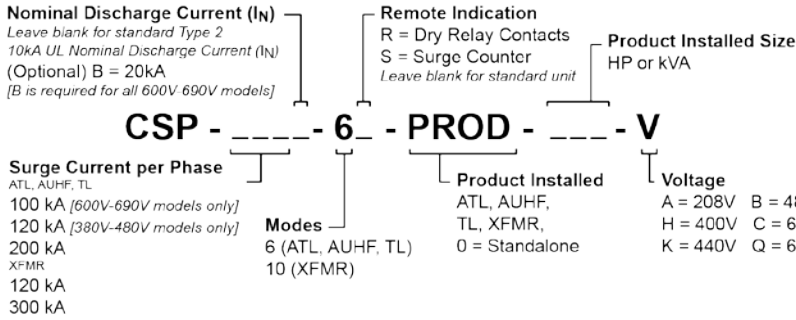

## STATUS LED INDICATORS DIMENSIONS STANDALONE DEVICE

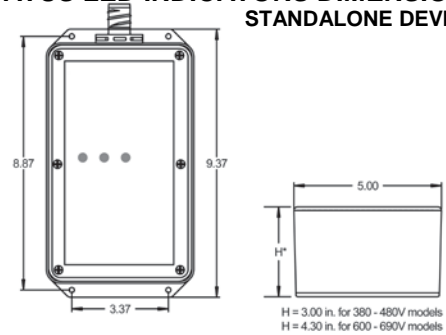

MODEL	SYSTEM VOLTAGE (3W+GND)	MCOV	PEAK SURGE CURRENT (PER MODE / PER PHASE)	MODE	PEAK LET-THROUGH VOLTAGE <sup>1</sup> Cat B3/C1 (6 kV, 3 kA) 90° Phase Angle
<i>PROD = ATL, AUHF, TL</i>					
CSP-120-6- <u>PROD</u> -B -H -K	380V – 480V	550 L-L 550 L-G	60 kA / 120 kA	L-L L-G	1472 1472
CSP-100B-6- <u>PROD</u> -C -Q	600V – 690V	840 L-L 840 L-G	50 kA / 100 kA		3000 2630
CSP-200-6- <u>PROD</u> -B -H -K	380V – 480V	550 L-L 550 L-G	100 kA / 200 kA		1472 1472
CSP-200B-6- <u>PROD</u> -C -Q	600V – 690V	840 L-L 840 L-G			3000 2630
CSP-120-6-XFMR-__A	208V	300 L-L 150 L-N 150 L-G 150 N-G	40 kA / 120 kA	L-L L-N L-G N-G	870 671 674 835
CSP-120-6-XFMR-__B -H -K	380V – 480V	550 L-L 320 L-N 320 L-G 320 N-G	40 kA / 120 kA		1483 1239 1267 1620
CSP-300-6- XFMR-__A	208V	300 L-L 150 L-N 150 L-G 150 N-G	100 kA / 300 kA		870 671 674 835
CSP-300-6- XFMR-__B -H -K	380V – 480V	550 L-L 320 L-N 320 L-G 320 N-G	100 kA / 300 kA		1483 1239 1267 1620

### Notes:

1. Peak let-through voltage defined as peak fundamental voltage + transient voltage, tested at 90deg (peak) of the fundamental waveform.
2. Please contact factory for additional options including 'Audible Alarm' or '25 year extended warranty on CSP component'.