

Using Lineator™ AUHF Harmonic Filter with a Adjustable Speed Drive equipped with Bypass

In previous Application Notes on this topic, Mirus has recommended that when bypassing an Adjustable Speed Drive (ASD) to feed the motor across-the-line, the Lineator™ AUHF should be bypassed with the ASD to ensure the voltage drop across the AUHF does not result in the motor being deprived of voltage. Although, this might still be required in some situations, Mirus has now **proven significant benefit in leaving the Lineator™ in the circuit when the ASD is bypassed.**

This new design approach may actually increase performance of the motor while in bypass mode. Even though there will be a voltage drop across the reactor, the Lineator™’s capacitors will compensate for the motor inductance which helps to support the voltage. In fact, the Lineator improves the motors power factor and acts similar to a reduced voltage starter to limit the motor inrush current.

These characteristics were proven in a field test of a standard Lineator™ AUHF-125-600-60-D-E1 used on a chilled water pump in a Data Center located in Guelph, Ontario, Canada. The Data Center is equipped with 80 Adjustable Speed Drives (ASD’s) ranging in size from 5 HP to 150 HP which control the motor speed on supply and return fans, cooling towers and chilled water pumps for the center’s Heating, Ventilating and Air-Conditioning (HVAC) system. An identical Data Center located in near London, Ontario has a similar number of ASD’s and Lineators™ with each ASD at both sites, equipped with a bypass circuit. It was not convenient to bypass the Lineator™ with the ASD, so a test was done on a 125 HP chilled water pump with and without the Lineator™ in the circuit while the ASD was being bypassed.

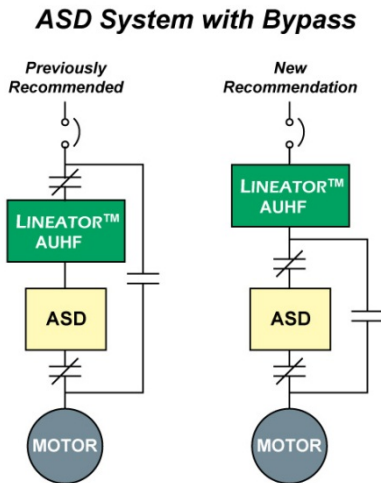

Figure 1: Single-line diagram of ASD system using The Lineator™ with a bypass circuit

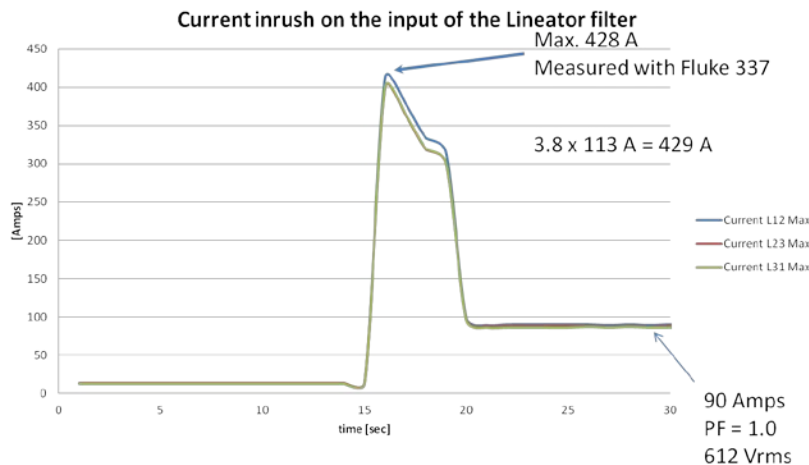

Figure 2: Motor current inrush measured on the input of the Lineator™ AUHF filter only 3.8 times the nominal.

Results were as follows:

- With Lineator™ AUHF included in the bypass circuit, the maximum recorded current inrush was 428 Amps.
- With Lineator™ AUHF removed from the circuit, the maximum recorded current inrush was 725 Amps.
- Due to the Lineator™'s capacitive reactance, the full load amps at nominal speed measured only 90 Amps, at near unity power factor and 612 Vrms as opposed to 102 Amps at PF = 0.867 with the Lineator™ by-passed.

The Lineator™ provided a low voltage start, measured at about 70% of the input line voltage. This limited the inrush current to 3.8x the nominal as opposed to 6.4x the nominal measured in an across-the-line start without the Lineator™. Provided the drop in voltage during inrush does not cause problems with the bypass control circuitry or with motor starting, the reduction in motor inrush can provide substantial benefit to other loads connected to the power system as the voltage drop they see will be substantially reduced.

The through impedance of the Lineator™ AUHF will also introduce up to 8% voltage drop during continuous motor operation across-the-line. Since motors are rated at voltages lower than nominal (ie. 460V when nominal is 480V) and are designed to operate with +10% and -10% voltage, this drop will normally not negatively affect motor operation. Leaving the Lineator™ in the circuit while the ASD is in bypass should therefore, be beneficial in the majority of cases. Some exceptions would be when:

- A 230V motor is fed by 208V.
- Nominal voltage is low.
- A long cable run to the motor results in significant voltage drop.
- The motor load requires a high starting torque such as constant torque applications.
- The ASD by-pass controls can't handle the voltage drop during inrush.
- The ASD is equipped with an output sinewave filter which is also kept in the circuit during by-pass. The significant voltage drop across the sinewave filter in addition to the Lineator voltage drop, will likely be too much for the motor to start properly.

With the improved PF and reduced voltage starting capability of the Lineator™ AUHF, Mirus now recommends for many applications, that it remain in the circuit when the ASD is bypassed. In fact, the Lineator™ might actually be a better solution than traditional soft start devices when starting a motor across-the-line.