



## A Practical Guide to Partial and Staged Harmonic Mitigation Strategies

One significant challenge in any detailed harmonic analysis is to understand which non-linear loads require harmonic mitigation to reach compliance with the recommended or required harmonic standard. Providing excess harmonic treatment and over-complicating the harmonic strategy can waste time, energy and money.

### **Partial Harmonic Mitigation (New or Existing Sites):**

A simple method that many engineers have adopted is to establish a maximum acceptable current total harmonic distortion (ITHD) level for the non-linear load and apply it to all sizes greater than a minimum rating. For example, if we're considering the variable speed drive (VSD) load in a facility, requiring a maximum full load ITHD of < 8% at the input terminals of all VSDs that are 30 HP and larger, will almost always ensure that IEEE Std 519 compliance is achieved.

This can be confirmed through the use of computer simulation software, such as Mirus' SOLV™, but in time experienced engineers will recognize that in many applications a formal harmonic analysis may no longer be required at the design stage; provided the correct harmonic mitigation technology is specified. This is because, when the majority of the non-linear load is treated such that harmonic current distortion will meet the standard's requirements at the load's input terminals, compliance will also be met upstream where the Point of Common Coupling (PCC) has been defined.

The advantage of not having to do a thorough harmonic analysis for each project is significant as the hours normally occupied for this can be applied to other electrical design challenges. Also, it is not always easy to do this analysis at the design stage when detailed load information is rarely available.

However, when the funds available for harmonic mitigation are limited by a project's budget, a detailed harmonic analysis might identify that

relaxing requirements on some non-linear loads will still result in compliance with the harmonic standard. While focusing on the larger and most heavily burdened non-linear loads, as well as, critical operation non-linear loads, a Partial Mitigation Strategy may allow you to achieve your harmonic goals without the need for extensive harmonic filtering.

So for new installations, the most effective approach should be to either require a maximum ITHD level for all non-linear loads above a certain HP or to use Partial Mitigation with modeling to determine an effective project profile. While for retrofit applications, Partial Mitigation in combination with a Staged Implementation Strategy may be the best course of action.

As stated above, a Partial Mitigation strategy can be achieved by evaluating the overall system and identifying significant harmonic loads for individual treatment, while focusing on overall system compliance to meet IEEE Std 519-1992 or -2014 targets or your specific target harmonic levels. Much like focusing on the forest by managing the trees. A detailed case example of a Partial Mitigation strategy can be found in the accompanying examples of Partial and Staged Harmonic Mitigation Strategy using SOLV™ Computer Simulation Software.

### **Staged Harmonic Mitigation (Existing Sites):**

Also, in retrofit applications, a second strategy that involves a Staged Harmonic Implementation can be considered. This 'staged' approach can be simple and very effective in controlling costs and other issues that might be created. The key is to control the implementation in manageable steps, through effective harmonic modeling and performance verification at each implementation stage. And to apply a harmonic mitigation technology that is tolerant of the high voltage distortion levels that might exist at the early stage of implementation when not all mitigation has been applied.

Accurate harmonic simulation software programs such as SOLV™, provide good approximations of the circuit condition, but in reality may not provide a perfectly clear and concise insight into the true circuit condition. This is understandable since load structures are variable and never totally accurate – both linear and non-linear. Also, within the circuit you can have secondary impedances and a host of other situations that can be difficult to determine. The idea of the model is to build a virtual map of the electrical circuit so that you can get to the right street within the ‘virtual circuit’ but not necessarily the exact address. If we are considering a retrofit application rather than new build, a staged implementation can allow you to ‘recalculate’ your mitigation direction at preset points to ensure that you have the right solution.

Each project is different but for extensive retrofits, breaking up the implementation into two to three stages is often beneficial. This involves taking harmonic measurements after deployment at each stage, then updating the models for observed conditions and load structures and modifying for the next stage, if required. Since it is wise to be conservative in the models initially, you may often find that by the end of the analysis, not as much mitigation is needed as was originally projected. But it is good to consider that the reverse may also be true.

A detailed example of a Staged Mitigation strategy for retrofit installations can also be found in the examples provided.

The staging implementation of the program is based on actual measurements versus theoretical calculation. This approach is particularly useful in analyzing Oil & Gas Electrical Submersible Pumps (ESPs) and Pipeline applications, Water and Waste Water for lift stations and other pumping applications, as well as, HVAC systems especially for

Medical Facility and Hospital installations. In fact, the concept of Partial Mitigation and Staged Implementation is briefly addressed in the Mirus white paper ‘TP-004A1, The Modern Hospital/Health Care Environment & Harmonics’. This paper was recently updated to reflect the latest developments relative to EC fan harmonics within HVAC Air-Handler installations. You can have access to our technical papers and installation guides via the following link:

<https://www.mirusinternational.com/downloads.php>

Other materials and information on the Mirus offering and technical data is available on our primary website:

<https://www.mirusinternational.com>

For more information or to solicit assistance with a particular project, please feel free to contact the Mirus office or more specifically:

**Michael A. McGraw**  
Regional Manager: Southern USA



33427 Mayer Rd  
Waller, TX 77484  
Cell: (713) 208-8534  
E-Mail: [m.mcgraw@mirusinternational.com](mailto:m.mcgraw@mirusinternational.com)

The following examples are intended to provide more detailed guidance of the Partial and Staged Harmonic Mitigation Strategies as described above. Analysis was performed using Mirus’ SOLV™ computer simulation software which can be freely downloaded at [www.mirusinternational.com](http://www.mirusinternational.com)



## Examples of Partial and Staged Harmonic Mitigation Strategy using SOLV™ Computer Simulation Software

### Partial Mitigation Strategy:

#### Overview and Step by Step Discussion

##### Source Condition Modeling

The first step is to build a basic overall model with source parameters, including source impedance/available short circuit, an approximation of the source voltage imbalance and background voltage distortion. Mirus SOLV™ software is used since it does what no other software does, which is to build an accurate model through the inclusion of background voltage distortion, Vd, and source voltage imbalance into the calculations to generate an accurate harmonic simulation. The harmonic spectrum for the non-linear loads is calculated based on a 'real world' scenario and not based on a simple look-up table without regard to loading and other critical parameters which can influence the analysis.

Source data can be entered as follows:

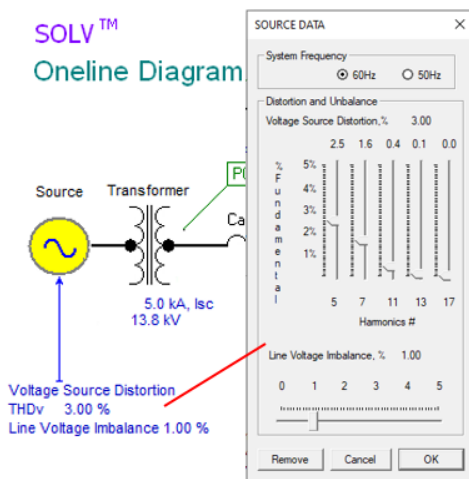

In this simulation, we have entered an existing 3% background Vd from the Utility with a prominent 5<sup>th</sup> order harmonic, which is fairly typical for Utility sources in industrial complex grid locations. Keep in mind, IEEE Std 519-2014 now allows voltage distortion levels of up to 8%, so simulations without any Utility distortion do not accurately reflect 'real world' conditions. We routinely find Utility Vd from

1.5% to 5% based on distance to the Substation, other Utility Users in the area, and other non-linear load structures within the facility itself. Even higher levels of Vd can be found where non-linear loads are a very high percentage of the overall loading or where the power system is 'weak' (ie. high source impedance). But a 2% to 3% estimate is what we typically use based on application and location. A harmonic measurement, if possible, is best and the Utility should be able to provide data if requested.

##### Source Impedance and Short Circuit Component:

The next step is to build the source itself - either a Utility/Substation transformer, Utility available Fault Level or Short Circuit Current, or possibly a Generator Supply. ***It is critical to model both a Utility Source and run a separate Back-up Generator Model if Back-up Generators are part of the circuit. The associated harmonic performance for any given load is a function of the source impedance characteristic. Due to the high impedance of a 'weak' source, Generator supplied systems will have much higher voltage distortion levels than a typical transformer supplied utility source when loaded by the same current harmonic load profile.***

For this model we will build two scenarios:

Scenario A: 13.8 kV, 5 kA available short circuit

Scenario B: 480V, 2500 kW Gen-Set with a subtransient reactance, X"d, of 16%

Also for Scenario B, we are going to change the voltage imbalance and background Vd to match a typical Generator Datasheet detail, which is 1.5% Vdbg and 1% Voltage Imbalance. It is also recommended that a copy of the Capacitance Reactance Withstand Curve of the Gen-Set be requested for later reference when evaluating possible harmonic mitigation solutions.

Utility Source Detail

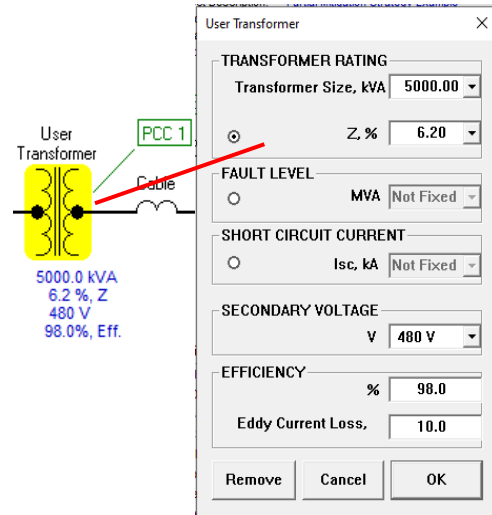
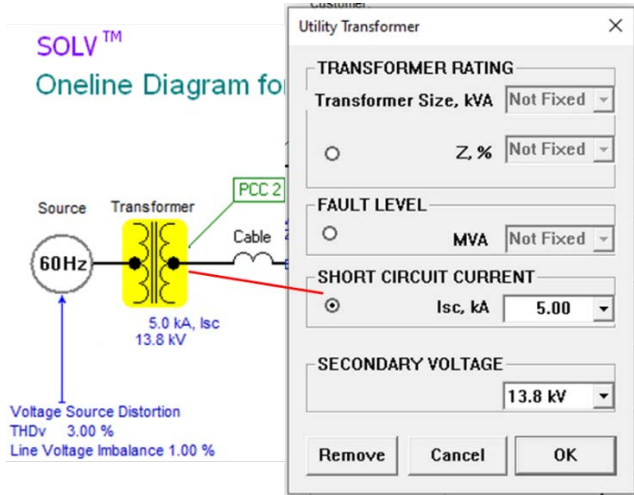

For Scenario B in this example, the back-up Gen-Set is supplying 480VAC so no User Transformer is required. But, if the Back-up Gen-Set is on the MV bus, then we would have to include the step down transformer within the Gen-Set analysis.

Gen-set Source Detail

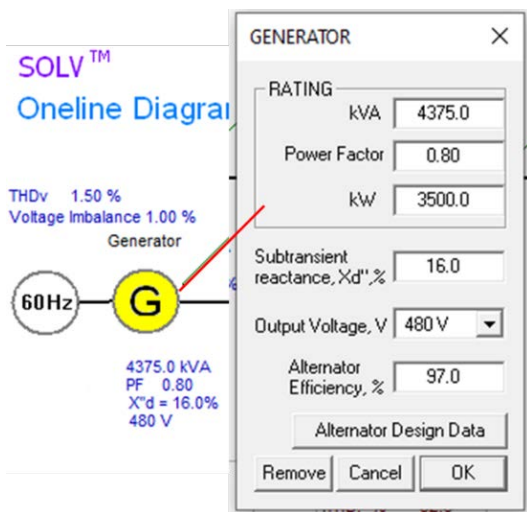

Other significant factors include system power factor correction. If you have these, it is important to know if reactors are included to tune or detune the capacitors, since both the capacity of the PF correction and its associated tuning can have a significant effect on the harmonics created. If present, simply click on the capacitor symbol to access a popup window to enter the associated data. If you do not place any data in these areas, then the input is not represented within the calculations, but the symbol is still shown. Make sure to determine the proper location of the PF correction capacitor data as you have two choices, ahead of the user transformer or after (i.e. in the example MV or LV).

The SOLV™ program can be set-up under a two scenario comparative mode saving time in building models and running 'what if' scenarios.

Other Significant Circuit Conditions:

Under Scenario A, we also have a User Transformer to include. Here we've chosen a 5000 kVA at 6.2% impedance transformer with the software defaults for efficiency and eddy losses. You can input the efficiency and losses if you have them but they do not affect harmonic calculations.

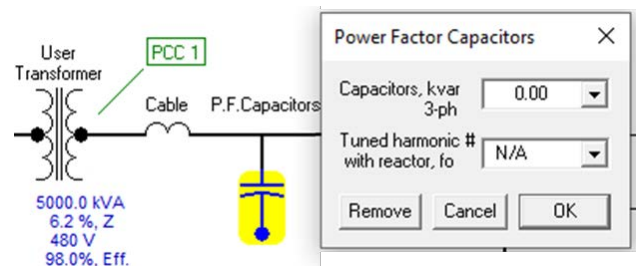

For cable runs, you can go into the detail of calculating approximate lengths and input the cable data by clicking the symbol. This can be used to fine

tune the models but for a conservative approach, the cable runs can be ignored unless they are very long. In the majority of installation evaluations, cable impedance has minimal effect on the outcome and ultimately, the worst case scenario is usually better represented by a conservative analysis.

#### Load Structure Profile:

Linear Loads: The first load branch within the SOLV™ software is for linear loads. The best practice is to review the design load schedules, isolate the nominal load value for the linear loads, and approximate a power factor based on the ratio of linear inductive structures (ie. fixed speed motors) versus resistive loads.

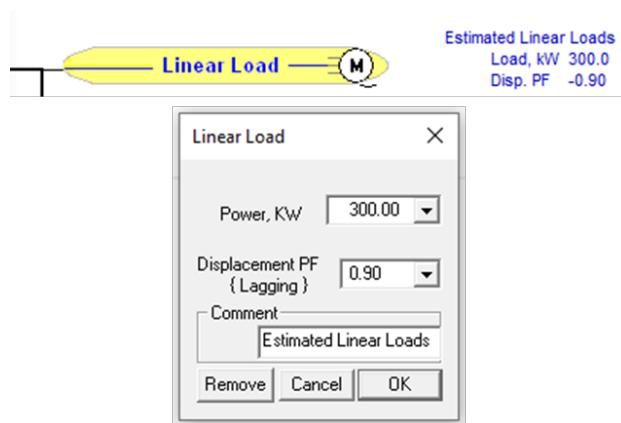

For this example, 300 kW linear load is chosen with a 0.9 PF to represent fixed speed induction motors.

Non-Linear Loads: When detailing and consolidating the non-linear loads, attention should be given to large individual drive loads and detailing their configuration, such as 6 pulse, 18 pulse, line side reactors, dc bus inductors, etc. They can be presented individually or consolidated in like types if enough non-linear load branches are not available (ie. more than 9 branches). For example, if six 50 HP, 6 pulse drives equipped with 3% reactors are in operation, they could be configured as a single 300 HP load within the simulation.

For most new projects, 6 pulse VFD's with or without line reactors or DC link inductors, determined by the preferred VFD vendor's normal configuration, will be modelled first to build a baseline. For this example, the following list of drives are used.

- Qty 1, 800 HP 6 pulse VFD with 3% DC Choke
- Qty 2, 400 HP 6 pulse, VFD with 3% DC Choke
- Qty 1, 200 HP 6 pulse, VFD with 3% DC Choke
- Qty 1, 125 HP 6 pulse VFD with 3% Line Reactor
- Qty 1, 75 HP 6 Pulse VFD with 3% Line Reactor
- Qty 5, 50 HP 6 pulse VFD with 3% Line Reactor
- Qty 4, 20 HP 6 pulse VFD with 3% Line Reactor

The model can also be configured to include auto-transformers or isolation transformers in each branch circuit to expand the 1-Line or provide phase shifting options. *Multi-pulse configuration drives can also be modeled effectively, but it should be noted that, phase shifting transformer topologies perform poorly in reducing harmonics when voltage imbalance and background voltage distortion are present. This does become evident when running multi-pulse VFD simulations in SOLV™ with voltage imbalance and/or voltage distortion present.*

Building the individual drive loads is easy, see example below for the 800 HP.

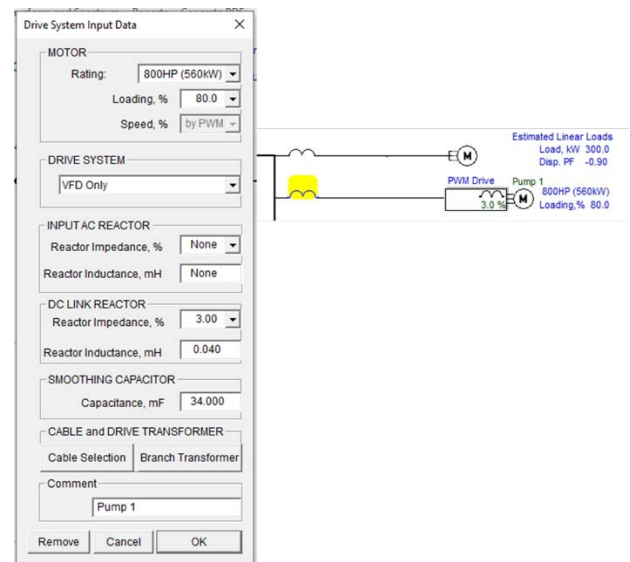

The first non-linear load branch (2<sup>nd</sup> including the linear branch) can be entered inputting the rating (800 HP), Loading % (max of 80% estimated), Drive System ('VFD only' to represent 6 pulse) and DC Link Reactor (3%). Also, the default smoothing capacitor for the VFD need not be changed. Other information such as cables and branch transformer could be entered if known and are present but none were used in this analysis.

Significant drive loads are then entered individually (i.e. 800 HP, 400 HP, 200 HP, etc.) in separated branches while the smaller, less significant loads such as the 50 HP and the 20 HP drives, are consolidated.

Once all data is entered, a simulation can be triggered by clicking on 'Run Simulation'. The One-Line Diagram for this base model with calculated results is as follows. After selecting 'Reports' and 'IEEE Std 519 Compliance Report', harmonic compliance can be reviewed on the following page.

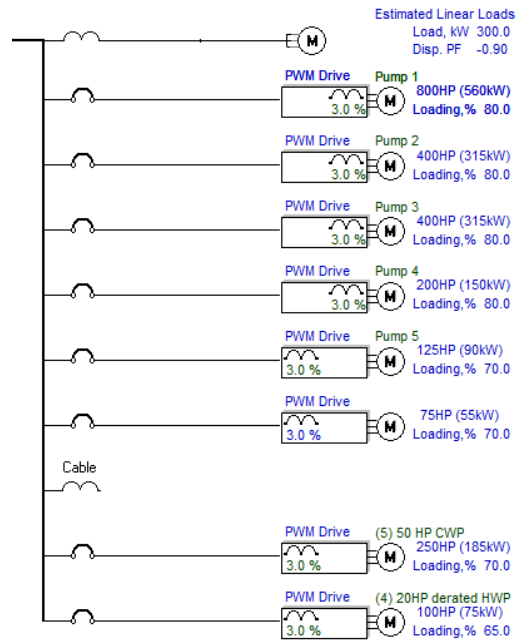

**Baseline Utility Source Evaluation (Scenario A):**

SOLV™  
Online Diagram for Scenario A

Project Name: Paper Model  
Project Description: Partial Mitigation Strategy Example  
Customer: M. McGraw Mirus US Southern Mfg.  
Prepared by: 5-APRIL-2020  
Date:



Switch to Scenario B

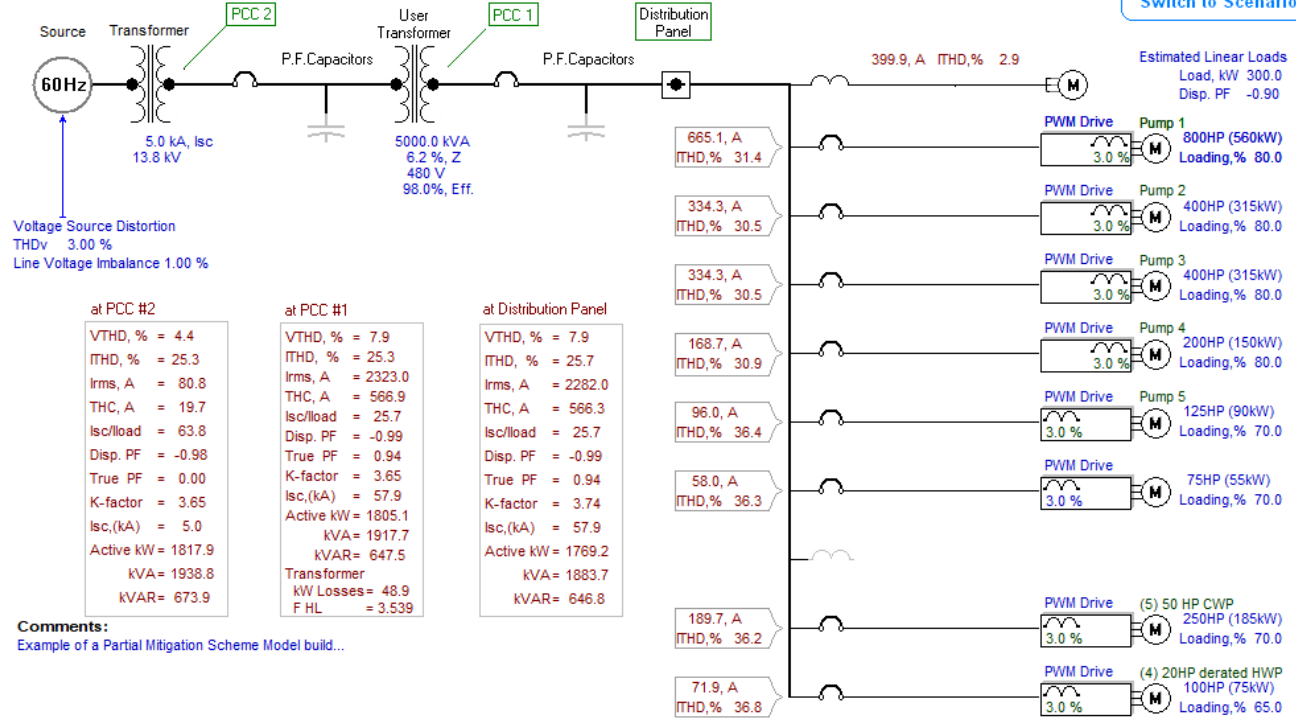

Comments:  
Example of a Partial Mitigation Scheme Model build...

Calculations are approximate values. Actual performance may vary due to field conditions.  
Sign convention for PF: -ve indicates lagging, +ve indicates leading.



### IEEE Std 519 Compliance Report

The following report describes the expected performance of a selected Variable Speed Drive(VSD) application under chosen conditions.

It includes a summary of the applications ability to meet IEEE Std 519:1992 and IEEE Std 519:2014 harmonic limits at the defined Point of Common Coupling (PCC) and has been prepared through the use of "SOLV" computer simulation software.

Calculations are approximate values. Actual performance may vary due to field conditions.

**Project Name:** Paper Model  
**Point of Coupling:** PCC #2  
**Bus voltage at PCC:** 13 kV  
**Short-circuit ratio:** 63.8

#### Summary of Compliance with IEEE Std 519:1992 and IEEE Std 519:2014 Harmonic Limits:

	Calculated Value, [%]	IEEE-519:1992 Limit, [%]		IEEE-519:2014 Limit, [%]	
Voltage Total Harmonic Distortion (VTHD)	4.4	5.0	PASS	5.0	PASS
Max.Individual Voltage Harmonic	3.8 { 5}	3.0	FAIL	3.0	FAIL
Current Total Demand Distortion (iTDD)	25.3	12.0	FAIL	12.0	FAIL
Max.Individual current harmonic	<11	10.0	FAIL	10.0	FAIL
	11 to 16	4.5	FAIL	4.5	FAIL
	17 to 22	4.0	PASS	4.0	PASS
	23 to 34	1.5	PASS	1.5	PASS
	>35	0.7	PASS	0.7	PASS

**Point of Coupling:** PCC #1  
**Bus voltage at PCC:** 480 V  
**Short-circuit ratio:** 25.7

#### Summary of Compliance with IEEE Std 519:1992 and IEEE Std 519:2014 Harmonic Limits:

	Calculated Value, [%]	IEEE-519:1992 Limit, [%]		IEEE-519:2014 Limit, [%]	
Voltage Total Harmonic Distortion (VTHD)	7.9	5.0	FAIL	8.0	PASS
Max.Individual Voltage Harmonic	6.0 { 5}	3.0	FAIL	5.0	FAIL
Current Total Demand Distortion (iTDD)	25.3	8.0	FAIL	8.0	FAIL
Max.Individual current harmonic	<11	7.0	FAIL	7.0	FAIL
	11 to 16	3.5	FAIL	3.5	FAIL
	17 to 22	2.5	PASS	2.5	PASS
	23 to 34	1.0	PASS	1.0	PASS
	>35	0.5	PASS	0.5	PASS

Notes: Based on the information provided, this application will NOT meet IEEE Std 519 harmonic limits

As can be seen, the application as configured in the base model does not meet the requirements of IEEE Std 519. The report shows the requirements for both the most recent revision of the standard, 2014, and the previous 1992 version. The principle difference between the two revisions is that voltage distortion limits for systems up to 1000V were increased in the 2014 version to < 8% from < 5%. Since some consultants and end-users still prefer to target the more severe limits, both requirements are presented and left for the user to choose.

The next step is to begin adding passive harmonic filters, first on the largest most significant loads, and rerunning the model until the targeted IEEE Std 519 limits are reached.

The targeted performance level will be determined by the requirements of the harmonic standard that you are desiring to meet and where these limits are to be applied (i.e. which PCC).

**Partial Mitigation - Utility Source (Scenario A):**

To achieve a better design, harmonic mitigation is applied on the largest drives in the form of a Mirus Lineator AUHF passive harmonic filter as shown below for the 800 HP unit. Line reactors or DC chokes can be removed as they provide little improvement when the filter is applied but can also remain if they are a built-in component.



For the first iteration, the 800 HP and 2 x 400 HP VFDs have filters applied. After rerunning the simulation and checking the IEEE Std 519 Compliance Report, the harmonic distortion levels have been lowered but remain above the required limits. This suggests that filters be added to the 200 HP and 125 HP VFDs to reduce harmonic current and voltage distortion further.

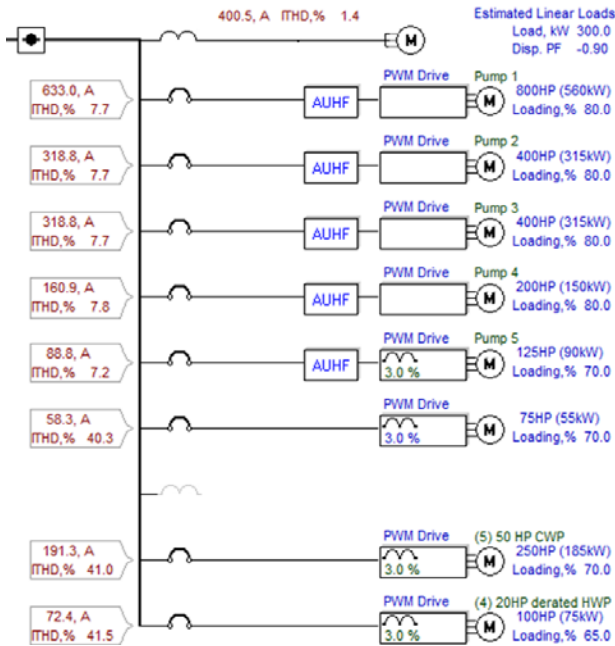

Point of Coupling: PCC #2  
 Bus voltage at PCC: 13 kV  
 Short-circuit ratio: 64.3

Summary of Compliance with IEEE Std 519:1992 and IEEE Std 519:2014 Harmonic Limits:

	Calculated Value, [%]	IEEE-519:1992 Limit, [%]	IEEE-519:2014 Limit, [%]
Voltage Total Harmonic Distortion (VTHD)	3.1	5.0	5.0
Max. Individual Voltage Harmonic	2.6 (5)	3.0	3.0
Current Total Demand Distortion (ITDD)	7.4	12.0	12.0
Max. Individual current harmonic	<11	10.0	10.0
	11 to 16	4.5	4.5
	17 to 22	4.0	4.0
	23 to 34	1.5	1.5
	>35	0.7	0.7

Point of Coupling: PCC #1  
 Bus voltage at PCC: 480 V  
 Short-circuit ratio: 25.9

Summary of Compliance with IEEE Std 519:1992 and IEEE Std 519:2014 Harmonic Limits:

	Calculated Value, [%]	IEEE-519:1992 Limit, [%]	IEEE-519:2014 Limit, [%]
Voltage Total Harmonic Distortion (VTHD)	3.7	5.0	8.0
Max. Individual Voltage Harmonic	2.7 (5)	3.0	5.0
Current Total Demand Distortion (ITDD)	7.4	8.0	8.0
Max. Individual current harmonic	<11	7.0	7.0
	11 to 16	3.5	3.5
	17 to 22	2.5	2.5
	23 to 34	1.0	1.0
	>35	0.5	0.5

Notes: Based on the information provided, this application will meet IEEE Std 519 harmonic limits

As can be seen, the application now meets all requirements of both IEEE Std 519 revisions at both the LV and MV PCCs, so no further mitigation is necessary when considering a Utility supply. The 75 HP and all 50 HP and 20 HP VFDs do not require any additional filtration.

However, if the system is equipped with a Back-up Generator source as described earlier, further analysis is warranted.

**Partial Mitigation - Generator Source (Scenario B):**

Keeping the same filtration mitigation strategy that we just established in Scenario A, we can switch to Scenario B and rerun the simulation with the Gen-Set as the supply.

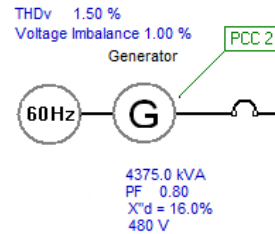



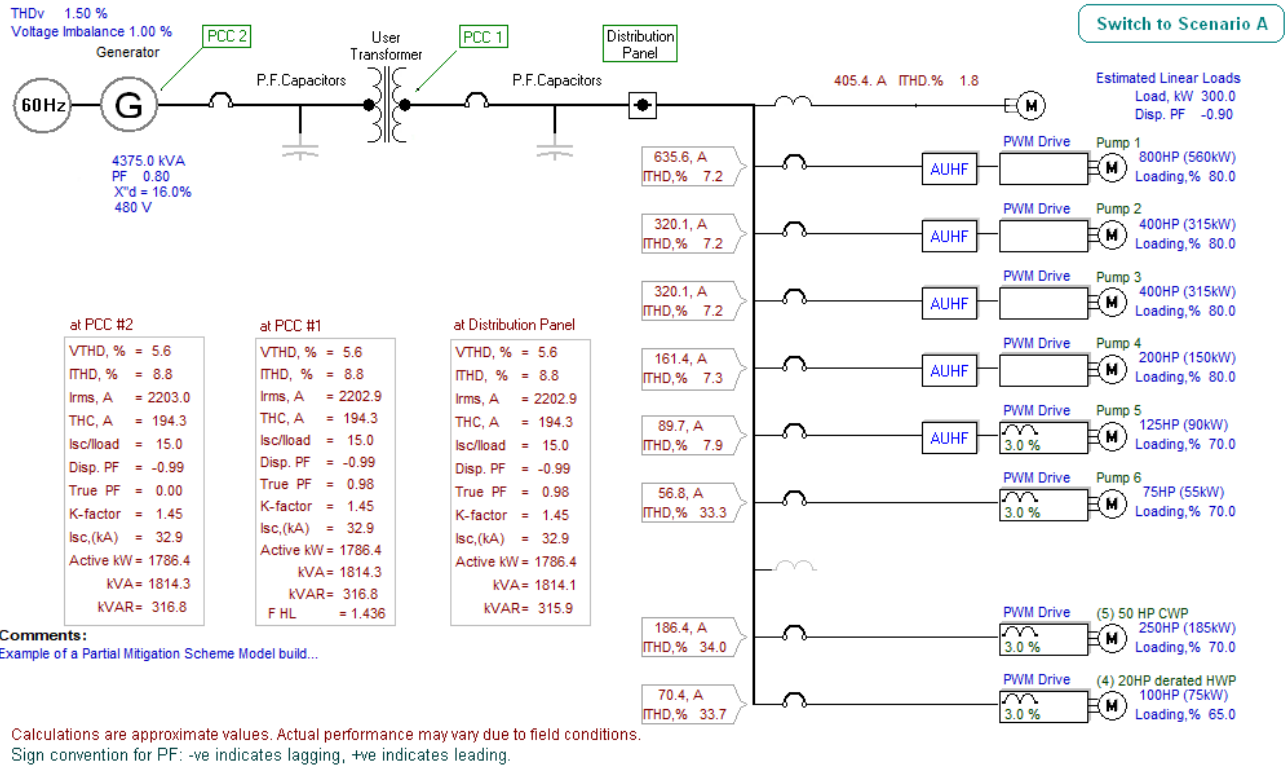

Checking the IEEE Std 519 Compliance Report, we see that the 1992 limits for voltage distortion are no longer met but 2014 limits are. So if 8% VTHD is determined to be acceptable, we only need to consider the current distortion limits.

Point of Coupling: PCC #2  
Bus voltage at PCC: 480 V  
Short-circuit ratio: 15.0  
Summary of Compliance with IEEE Std 519:1992 and IEEE Std 519:2014 Harmonic Limits:

	Calculated Value, [%]	IEEE-519:1992 Limit, [%]	IEEE-519:2014 Limit, [%]		
Voltage Total Harmonic Distortion (VTHD)	5.6	5.0	8.0	FAIL	PASS
Max. Individual Voltage Harmonic	3.5 (7)	3.0	5.0	FAIL	PASS
Current Total Demand Distortion (ITDD)	8.8	5.0	5.0	FAIL	FAIL
Max. Individual current harmonic	<11	4.0	4.0	FAIL	FAIL
	11 to 16	2.0	2.0	FAIL	FAIL
	17 to 22	1.5	1.5	PASS	PASS
	23 to 34	0.6	0.6	PASS	PASS
	>35	0.3	0.3	PASS	PASS

However, the challenge with the current distortion limits is that the short circuit ratio has reduced to 15 due to the higher impedance of the generator source. Being below 20, reduces the overall current distortion limit to < 5% ITDD and also reduces the individual harmonic current limits, resulting in these limits not being met.

Since IEEE Std 519 was developed as a Utility standard, some may choose not to apply these limits while on generator supply and accept the harmonic

mitigation strategy as applied for the Utility supply. However, considering that voltage distortion increases when on a 'weaker' source, harmonic problems can often become evident in an emergency situation when running on back-up power.

If this approach is contemplated, a review of the Gen-Set specification might be in order to determine if the Generator package can handle the projected current harmonic and if there would be any anticipated challenges for the voltage regulator to handle the associated voltage distortion.

Also, since passive harmonic filters are being applied, analysis of the generator's ability to handle capacitive reactive power should be done. At < 15%, Mirus Lineator filters have a very small capacitive reactance to full power ratio. In the partial mitigation scenario established earlier, the total filter load is 1925 HP or 1436 kW. 15% of this is 215 kW so the maximum filter capacitance would be 215 kVAR. As a percent of the generator's 4375 kVA full rated capacity, the filter maximum capacitive

reactance is only 5% which would be well within the generator's acceptable levels.

So a decision to accept the partial harmonic mitigation as defined in the Utility analysis may be justified. But, if IEEE Std 519 limits are required to be

met on generator supply as well as Utility supply, some additional mitigation is necessary.

Adding harmonic filters to all VFDs and rerunning the simulation produces the following results.

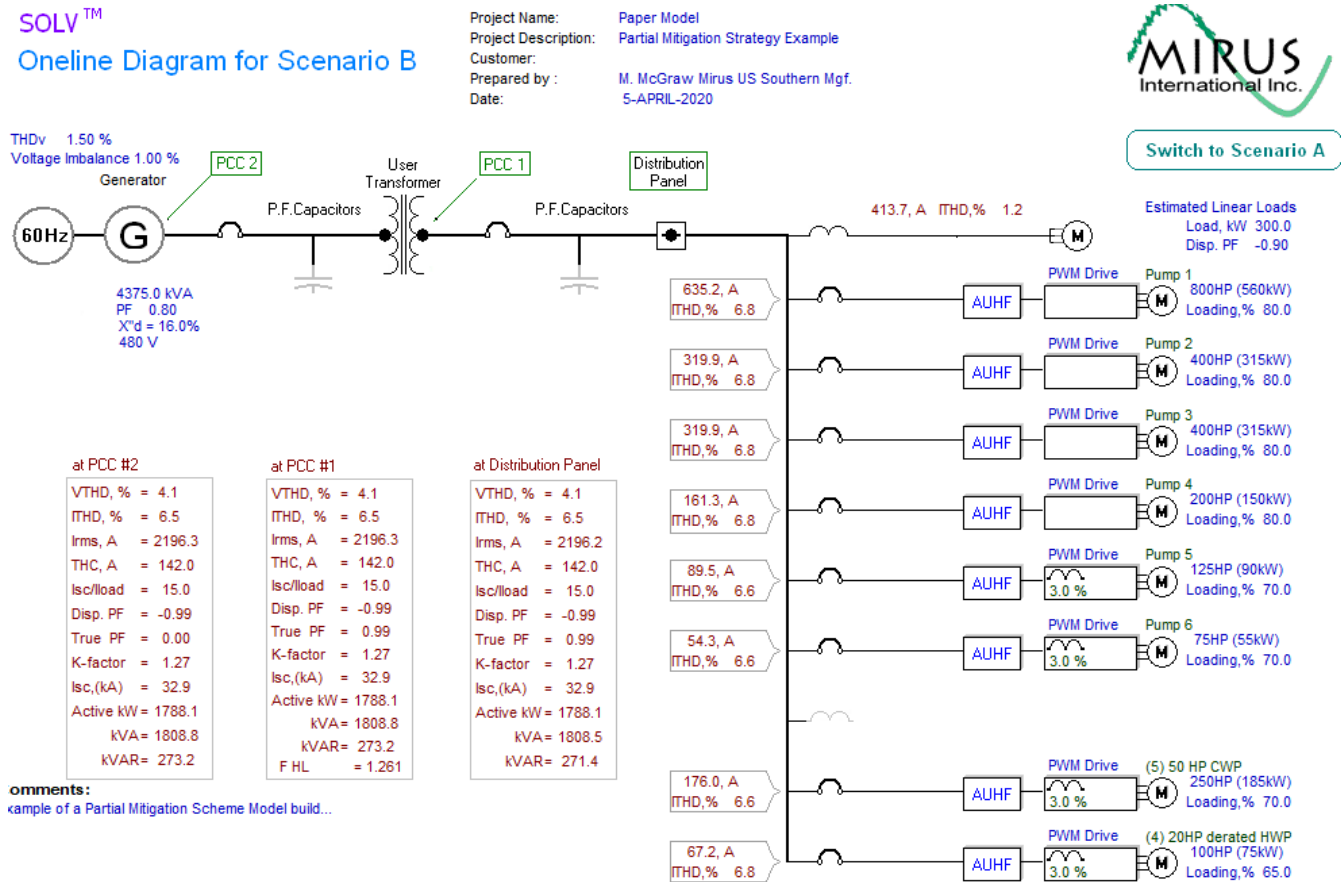

Checking the IEEE Std 519 Compliance Report, we see that, although voltage distortion levels have now been reduced below both 1992 and 2014 limits, the current distortion values are still not quite met.

A harmonic mitigation strategy that totally meets IEEE Std 519 will require the use of high performance Lineator AUHF-HP filters that achieve < 5% ITDD. The need for this is debatable however, since these low current distortion levels are unlikely to cause any problems and VTHD levels are quite low already.

Point of Coupling: PCC #2  
 Bus voltage at PCC: 480 V  
 Short-circuit ratio: 15.0

Summary of Compliance with IEEE Std 519:1992 and IEEE Std 519:2014 Harmonic Limits:

	Calculated Value, [%]	IEEE-519:1992 Limit, [%]		IEEE-519:2014 Limit, [%]	
Voltage Total Harmonic Distortion (VTHD)	4.1	5.0	PASS	8.0	PASS
Max. Individual Voltage Harmonic	2.9 (7)	3.0	PASS	5.0	PASS
Current Total Demand Distortion (ITDD)	6.5	5.0	FAIL	5.0	FAIL
Max. Individual current harmonic	<11	4.0	FAIL	4.0	FAIL
	11 to 16	2.3 (11)	FAIL	2.0	FAIL
	17 to 22	0.9 (17)	PASS	1.5	PASS
	23 to 34	0.4 (25)	PASS	0.6	PASS
	>35	0.1 (37)	PASS	0.3	PASS

In summary, fine tuning and modifying the modeling to find the right mix to achieve your harmonic targets is manageable and can save significant investment in materials and labor by not requiring harmonic mitigation on all of the non-linear loads, just enough of them.

## Staged Mitigation Strategy:

### Example for Retrofit Harmonic Mitigation Projects

If the previous example was being analyzed for a retrofit application, budget constraints could justify a staged mitigation strategy as follows:

#### Stage 1 - Utility Source (Scenario A):

The 800 HP and two 400 HP VFD's could be mitigated first followed by field measurements to compare actual performance with simulation results.

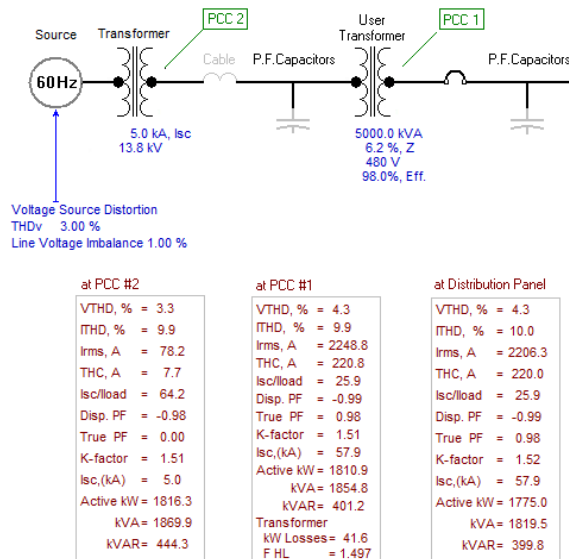

Simulations show a significant reduction in current harmonic distortion and voltage distortion is lowered to < 5%. After installation, a measurement can be taken at PCC 1 with a Power Quality Meter and compared with the simulation to determine how close actual results are to the anticipated performance. If confirmed by measurement and any operational issues have been resolved, this might be the only mitigation required.

If measured performance is not as good as predicted or problems remain, additional mitigation could be applied to the 200 HP or both the 200 HP and 125 HP VFDs as Stage 2.

#### Stage 2 – Utility Source (Scenario A):

Revisiting the computer simulation with additional filtering on the 200 HP and 125 HP VFDs results in the following:

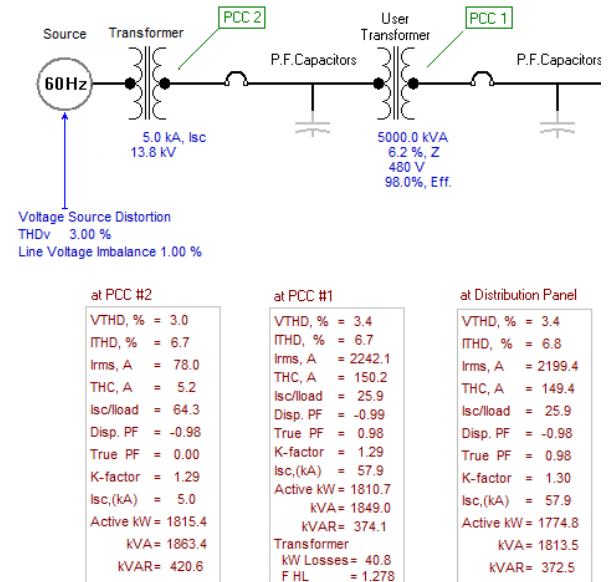

This results in both current and voltage distortion meeting the requirements of IEEE Std 519. If confirmed by measurement, this should be all the harmonic mitigation required

The same staged approach can be applied to Scenario B – Generator Supply, but due to the higher source impedance, the first Stage may suggest more harmonic mitigation than just the 800 HP and the two 400 HP VFDs.

For more information or to solicit assistance with a particular project, please feel free to contact:

**Michael A. McGraw**  
Regional Manager: Southern USA



33427 Mayer Rd  
Waller, TX 77484  
Cell: (713) 208-8534  
E-Mail: m.mcgraw@mirusinternational.com

Or our general office as noted below.